

**GENETIC VARIABILITY AND CHARACTER ASSOCIATION IN F₂
GENERATION OF TOMATO (*Solanum lycopersicum* L.)**

NAZMIN ARA



**DEPARTMENT OF GENETICS AND PLANT BREEDING
SHER-E-BANGLA AGRICULTURAL UNIVERSITY
DHAKA-1207**

JUNE, 2021

**GENETIC VARIABILITY AND CHARACTER ASSOCIATION IN F₂
GENERATION OF TOMATO (*Solanum lycopersicum* L.)**

BY

NAZMIN ARA

REGISTRATION NO. 19-10054

**A thesis
submitted to the Faculty of Agriculture
Sher-e-Bangla Agricultural University, Dhaka,
in partial fulfillment of the requirements
for the degree of**

MASTER OF SCIENCE

IN

GENETICS AND PLANT BREEDING

SEMESTER: JANUARY-JUNE, 2021

Approved by:

**Prof. Dr. Naheed Zeba
Supervisor**

**Prof. Dr. Firoz Mahmud
Co-Supervisor**

**Prof. Dr. Md. Abdur Rahim
Chairman
Examination Committee**



Prof. Dr. Naheed Zeba

Department of Genetics and Plant Breeding
Sher-e-Bangla Agricultural University
Dhaka-1207, Bangladesh

Phone: +8802-9180921-167 (Office)

Mobile: +88 01913-091772

E-mail: zeban@sau.edu.bd

CERTIFICATE

*This is to certify that thesis entitled, "GENETIC VARIABILITY AND CHARACTER ASSOCIATION IN F₂ GENERATION OF TOMATO (*Solanum lycopersicum* L.)" submitted to the Faculty of Agriculture, Sher-e-Bangla Agricultural University, Dhaka, in partial fulfillment of the requirements for the degree of **MASTER OF SCIENCE IN GENETICS AND PLANT BREEDING**, embodies the result of a piece of bona fide research work carried out by **NAZMIN ARA**, Registration number 19-10054 under my supervision and guidance. No part of the thesis has been submitted for any other degree or diploma.*

I further certify that such help or source of information, as has been availed of during the course of this investigation has duly been acknowledged.

Dated: June, 2021
Dhaka, Bangladesh

(Prof. Dr. Naheed Zeba)
Supervisor

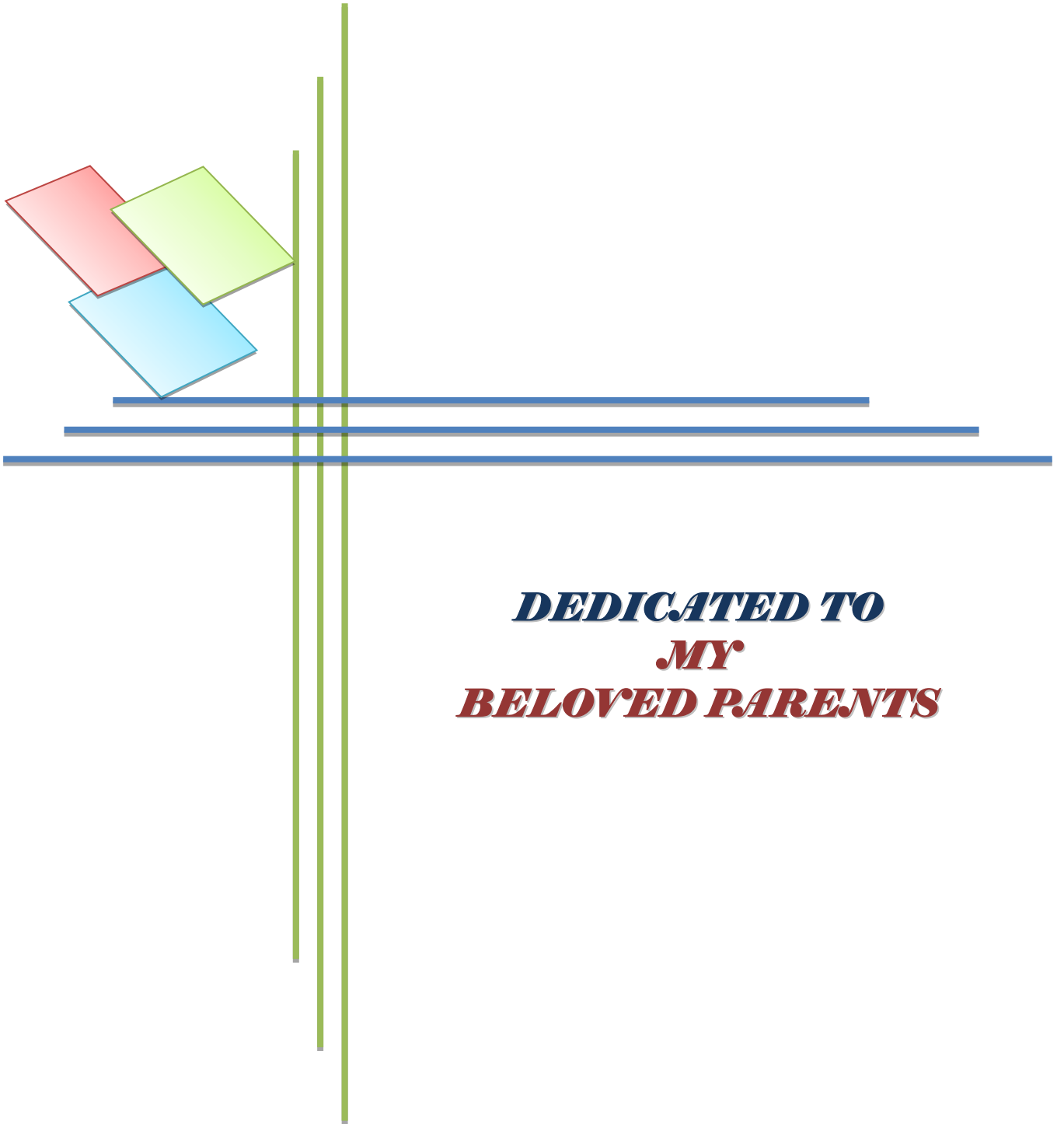

***DEDICATED TO
MY
BELOVED PARENTS***

Some commonly used abbreviations

Full word	Abbreviation	Full word	Abbreviation
Abstract	<i>Abstr.</i>	Information	<i>Inf.</i>
Advances/Advanced	<i>Adv.</i>	International	<i>Intl.</i>
Agriculture	<i>Agric.</i>	Journal	<i>J.</i>
Agricultural	<i>Agril.</i>	Kilogram	Kg
Agronomy	<i>Agron.</i>	Limited	<i>Ltd.</i>
And others	<i>et al.</i>	Ministry	<i>Min.</i>
Analysis of Variance	ANOVA	Muriate of Potash	MP
Applied	<i>Appl.</i>	Negative logarithm of	pH
Archives	<i>Arch.</i>	hydrogen ion	
Bangladesh Bureau of		concentration (-log	
Statistics	BBS	[H ⁺])	
Biology	<i>Biol.</i>	Non-significant	ns
Botany	<i>Bot.</i>	Mid parent	MP
Better parent	BP	Parts per million	Ppm
Breeding	<i>Breed.</i>	Percentage	%
Centimeter	Cm	Proceedings	<i>Proc.</i>
Coefficient of variation	CV	Programme	<i>Prog.</i>
Cross between two		Randomized Complete	RCBD
dissimilar parents	X	Block Design	
Degree Celsius	°C	Replication	<i>Rep.</i>
Ecology	<i>Ecol.</i>	Research	<i>Res.</i>
Economic	<i>Econ.</i>	Review	<i>Rev.</i>
Environment	<i>Environ.</i>	Science	<i>Sci.</i>
Etcetera	etc.	Serial	Sl.
Experimental	<i>Expt.</i>	Society	<i>Soc.</i>
Food and Agricultural		Specific combining	SCA
Organization	FAO	ability	
Gazette	<i>Gaz.</i>	That is	i.e.
General	<i>Gen.</i>	The second generation	
General combining	GCA	of a cross between two	F₂
ability (GCA)		dissimilar parents	
		Triple Super	TSP
Genetics	<i>Genet.</i>	Phosphate	
Gram	G	University	<i>Uni.</i>
Heredity	<i>Hered.</i>	Variety	<i>var.</i>
Horticulture		Vegetable	<i>Veg.</i>
Horticultural	<i>Hort.</i>	Videlicet (namely)	<i>viz.</i>
Incorporated	<i>Inc.</i>	Weight	wt.

ACKNOWLEDGEMENTS

At first the author expresses her profound gratitude to the Almighty Allah for never-ending blessings to complete this research work successfully. It is a great pleasure to express her reflective gratitude to her respected and beloved parents and teachers who entiled much hardship inspiring for prosecuting her studies by receiving a proper education.

The author would like to express her earnest respect, sincere appreciation and enormous thankfulness to her reverend, heartedly respected and beloved supervisor, Prof. Dr. Naheed Zeba, Department of Genetics and Plant Breeding, Sher-e-Bangla Agricultural University (SAU), Dhaka for her scholastic supervision, constructive, knowledgeable and insightful suggestions, continuous encouragement and unvarying inspiration throughout the research work, and for taking immense care just like a family during the study and the preparation of this manuscript.

The author also expresses her heartiest gratitude and respect to her honorable Co-Supervisor, Prof. Dr. Firoz Mahmud, Department of Genetics and Plant Breeding, Sher-e-Bangla Agricultural University (SAU), Dhaka for his guidance, suggestions, encouragement and valuable teaching which was very helpful during the final stretch of her thesis writing.

The author is very much grateful to her honorable teacher Prof. Dr. Md. Abdur Rahim, Chairman, Department of Genetics and Plant Breeding, Sher-e-Bangla Agricultural University (SAU), Dhaka for his valuable and knowledgeable teaching and guidance during her study period as well as constructive suggestions, encouragement and heartedly cooperation during the whole research period.

The author feels very grateful to Prof. Dr. Md. Shahidur Rashid Bhuiyan, Honourable Vice-chancellor, Sher-e-Bangla Agricultural University, Dhaka and Prof. Dr. Alok Kumar Paul, Honourable Dean, Post Graduate Studies, Agriculture faculty for giving every possible logistic support, valuable suggestions and cooperation during the whole study period.

The author feels to express her heartfelt thanks and deepest gratitudes to her all respectable teachers, specially honourable Prof. Dr. Md. Sarowar Hossain, Dr. Md. Ashaduzzaman Siddiquee, Dr. Md. Harun-Ur-Rashid, Dr. Md. Abdur Rahim, Dr. Shahanaz Parveen, Ms. Kamrunnahar and all other honourable course instructors of the Department of Genetics and Plant Breeding, Sher-e-Bangla

Agricultural University, Dhaka for their valuable teaching, direct and indirect advices, encouragement and continuous warm cooperation during the period of her study.

The author is very grateful to Mosammat Rexona Parvin and Shyamol Kumar Roy, academic officers and wants to give thanks to all the staff members of the Department of Genetics and Plant Breeding, Sher-e-Bangla Agricultural University, Dhaka for their continuous cooperation throughout the study period. It was also a great pleasure to work with her seniors Asmaul Husna, Abu Bakkar Siddique, and her classmates Eapshita Devi and Onusha Sharmita, students of the Department of Genetics and Plant Breeding and many of her classmates and Md Abu Hanjala, junior fellow MS student to whom the author was close throughout her institutional study and research period. It was an amazing experience to work with all of them.

Moreover, the author imparts her heartiest love and respect to her parents for their support, continuous encouragement and inspiration who sacrificed much for her education and upbringing. She can never repay their debt. The author wants to thank those peoples who helped, supported, assisted and inspired the author in various ways with their valuable suggestions and directions to achieve her dream of higher education. She is unreservedly thankful, expresses her heartiest gratefulness to all of them as well as she regrets her inability for not mentioning everyone by name, and heartedly requests for their forgiveness.

The Author

LIST OF CONTENTS

CHAPTER	TITLE	PAGE NO.
	ABBREVIATIONS	i
	ACKNOWLEDGEMENTS	ii-iii
	LIST OF CONTENTS	iv-ix
	LIST OF TABLES	x
	LIST OF PLATES	x
	LIST OF APPENDICES	xi
	ABSTRACT	xii
I	INTRODUCTION	1-3
II	REVIEW OF LITERATURE	4-27
	2.1 Tomato	4-6
	2.1.1 Nomenclature, origin and distribution of tomato	4-5
	2.1.2 Nutritional and medicinal value of tomato	5-6
	2.2 Variability	6-16
	2.2.1 Days to first flowering	8
	2.2.2 Plant height	9-10
	2.2.3 Days to maturity	10
	2.2.4 Number of branches per plant	10-11
	2.2.5 Number of clusters per plant	11-12
	2.2.6 Number of fruits per cluster	12
	2.2.7 Number of fruits per plant	12-13
	2.2.8 Fruit length	13-14
	2.2.9 Fruit diameter	14
	2.2.10 Fruit Weight	14-15
	2.2.11 Yield per plant	15-16
	2.3 Heritability and genetic advance	16-19
	2.4 Correlation co-efficient analysis between yield and yield contributing characters	19-23

LIST OF CONTENTS (CONT'D)

CHAPTER	TITLE	PAGE NO.
	2.5 Path co-efficient analysis between yield and yield contributing characters	23-25
	2.6 Chemical analysis	25-27
	2.6.1 Total soluble solids	26-27
	2.6.2 pH	27
III	MATERIALS AND METHODS	28-47
	3.1 Experimental site	28
	3.2 Planting materials	28
	3.3 Soil and climate	28-30
	3.4 Seed bed preparation and seedling raising	30
	3.5 Design and layout	30
	3.6 Land preparation	30-32
	3.7 Manure and fertilizer dose	32
	3.8 Transplanting of seedlings	32
	3.9 Intercultural operations	32-34
	3.10 Harvesting and Processing	34
	3.11 Data recording	35-40
	3.11.1 Agro-morphological traits	35
	3.11.1.1 Days to first flowering	35
	3.11.1.2 Days to 50% flowering	35
	3.11.1.3 Days to first fruiting	35
	3.11.1.4 Days to maturity	35
	3.11.1.5 Plant height	35-36
	3.11.1.6 Number of branches per plant	37
	3.11.1.7 Number of clusters per plant	37

LIST OF CONTENTS (CONT'D)

CHAPTER	TITLE	PAGE NO.
	3.11.1.8 Number of flowers per cluster	37
	3.11.1.9 Number of fruits per cluster	37
	3.11.1.10 Number of fruits per plant	37
	3.11.1.11 Fruit length	37
	3.11.1.12 Fruit diameter	37
	3.11.1.13 Skin diameter	38
	3.11.1.14 Locule number	38
	3.11.1.15 Individual fruit weight	38
	3.11.1.16 Fruit yield per plant	38
	3.11.2 Nutritional traits	38-40
	3.11.2.1 Determination of fruit pH	38
	3.11.2.2 Brix percentage (%)	39
	3.11.3 Physiological traits	39-40
	3.11.3.1 Relative water content	39
	3.11.3.2 Moisture percentage	39-40
	3.12 Statistical analysis	41-47
	3.12.1 Estimation of genotypic and phenotypic variances	41
	3.12.2 Estimation of genotypic and phenotypic coefficient of variation	42
	3.12.3 Estimation of heritability	42
	3.12.4 Estimation of genetic advance	42-43
	3.12.5 Estimation of genetic advance mean's percentage	43
	3.12.6 Estimation of simple correlation co-efficient	43
	3.12.7 Estimation of genotypic and phenotypic correlation Coefficient	44
	3.12.8 Estimation of path co-efficient	44-47

LIST OF CONTENTS (CONT'D)

CHAPTER	TITLE	PAGE NO.
IV	RESULTS AND DISCUSSION	48-81
	4.1 Genetic parameters	48
	4.2 Genetic variability, heritability and genetic advance	48-62
	4.2.1 Days to first flowering	49-51
	4.2.2 Days to 50% flowering	51
	4.2.3 Days to first fruiting	51-52
	4.2.4 Days to maturity	52
	4.2.5 Plant height	52-53
	4.2.6 Number of branches per plant	53
	4.2.7 Number of clusters per plant	54
	4.2.8 Number of flowers per cluster	54-55
	4.2.9 Number of fruits per cluster	55
	4.2.10 Number of fruits per plant	55-56
	4.2.11 Fruit length	56
	4.2.12 Fruit diameter	57
	4.2.13 Skin diameter	57
	4.2.14 Locule number	58
	4.2.15 Total soluble solids	58-59
	4.2.16 pH	59
	4.2.17 Relative water content	59-60
	4.2.18 Moisture percentage	60
	4.2.19 Individual fruit weight	60-61
	4.2.20 Yield per plant	61-62
	4.3 Correlation Co-efficient	62-71
	4.3.1 Days to first flowering	62-63
	4.3.2 Days to 50% flowering	63-65

LIST OF CONTENTS (CONT'D)

CHAPTER	TITLE	PAGE NO.
	4.3.3 Days to first fruiting	65
	4.3.4 Days to maturity	65-66
	4.3.5 Plant height	66
	4.3.6 Number of branches per plant	66-67
	4.3.7 Number of clusters per plant	67
	4.3.8 Number of flowers per cluster	68
	4.3.9 Number of fruits per cluster	68
	4.3.10 Number of fruits per plant	69
	4.3.11 Fruit length	69
	4.3.12 Fruit diameter	69
	4.3.13 Skin diameter	70
	4.3.14 Locule number	70
	4.3.15 Total soluble solids	70
	4.3.16 pH	70
	4.3.17 Relative water content	70-71
	4.3.18 Moisture percentage	71
	4.3.19 Individual fruit weight	71
	4.4 Path Co-efficient Analysis	71-81
	4.4.1 Days to first flowering	72
	4.4.2 Days to 50% flowering	72-74
	4.4.3 Days to first fruiting	74
	4.4.4 Days to maturity	74
	4.4.5 Plant height	75
	4.4.6 Number of branches per plant	75
	4.4.7 Number of clusters per plant	75-76
	4.4.8 Number of flowers per cluster	76
	4.4.9 Number of fruits per cluster	76-77

LIST OF CONTENTS (CONT'D)

CHAPTER	TITLE	PAGE NO.
	4.4.10 Number of fruits per plant	77
	4.4.11 Fruit length	77
	4.4.12 Fruit diameter	78
	4.4.13 Skin diameter	78
	4.4.14 Locule number	78-79
	4.4.15 Total soluble solids	79
	4.4.16 pH	79
	4.4.17 Relative water content	80
	4.4.18 Moisture percentage	80
	4.4.19 Individual fruit weight	80-81
V	SUMMARY AND CONCLUSION	82-87
	REFERENCES	88-101
	APPENDICES	102-117

LIST OF TABLES

TABLE NO.	TITLE	PAGE NO.
1.	Name and origin of 39 tomato genotypes used in the present study	29
2.	Doses of manures and fertilizers used in the experiment	32
3.	Estimation of parameters of 39 genotypes in tomato	50
4.	Genotypic and phenotypic correlation coefficients among different pairs of yield and yield contributing characters for 39 genotypes	66
5.	Path coefficient analysis showing direct (bold) and indirect effects of different characters on yield of tomato	76

LIST OF PLATES

PLATE NO.	TITLE	PAGE NO.
1.	Different seedling stage on seedbed	31
2.	Land preparation and different intercultural operations	33
3.	Data collection and harvesting of fruits	36
4.	Data collection for nutritional traits	40

LIST OF APPENDICES

APPENDIX NO.	TITLE	PAGE NO.
I.	Map showing the experimental site under the study	102
II.	Morphological, physical and chemical characteristics of initial soil (0-15 cm depth) of the experimental site	103
III.	Monthly records of air temperature, relative humidity, rainfall and sunshine hours of the experimental site during the period from November 2019 to March 2019	104
IV.	Layout of the experimental design	105
V.	Analysis of variance for 20 characters of 39 tomato genotypes	106
V.	Mean performance of various growth parameters and yield components of 39 genotypes of tomato	107-116
VI.	Pictorial views of the experimental field	117

GENETIC VARIABILITY AND CHARACTER ASSOCIATION IN F₂ GENERATION OF TOMATO (*Solanum lycopersicum* L.)

ABSTRACT

The experiment was conducted at Sher-e-Bangla Agricultural University, Dhaka, Bangladesh during the Rabi season of 2019 under field condition to identify the variability, correlation and path coefficient analysis by considering twenty (20) yield contributing characters using thirty-nine (39) crossing genotypes in F₂ generation of tomato (*Solanum lycopersicum* L.). The genotype G₄×G₅ showed the highest number of flowers per cluster but the genotype G₆×G₅ showed the highest number of fruits per cluster and the genotype G₃×G₁ showed the highest number of fruits per plant. The genotype G₁×G₄ showed the highest fruit diameter, locule number, individual fruit weight (61 g) and fruit yield per plant (4.62 kg) but lowest total soluble solids, pH and moisture percentage. The genotypes G₆×G₇ and G₇×G₆ showed earlier period of days to 50% flowering (72 DAT) and first fruiting (49.33 DAT) where the earlier period of days to maturity was found in G₂×G₅ (89.67 DAT), respectively. Narrow gap between PCV and GCV for days to 50% flowering, days to maturity, fruit length, fruit diameter, skin diameter, locule number, total soluble solids, pH, relative water content, moisture percentage, individual fruit weight and fruit yield per plant suggested that environmental influence were minor on the expression of the gene controlling these traits and selection based upon the phenotypic expression of these characters would be effective for the improvement of this crop. High heritability coupled with high genetic advance in percentage of mean for fruit length (cm), fruit diameter (cm), skin diameter (mm), locule number, total soluble solids, pH, relative water content, individual fruit weight and fruit yield per plant were obtained, suggesting that the heritability of these traits is due to additive gene effects and selection may be effective in early generations for these traits. Yield per plant showed positively significant association with number of flowers per cluster, fruit length, fruit diameter, locule number, individual fruit weight for both genotypic and phenotypic level, indicating that a possible increase in these traits tends to increase in fruit yield per plant. A positive direct effect was obtained for days to first fruiting, number of branches per plant, number of clusters per plant, number of fruits per cluster, skin diameter, locule number, relative water content, moisture percentage and individual fruit weight on fruit yield per plant. Therefore, considering the agronomic and genetical performance, the G₁×G₄ genotype for high yield, G₆×G₇ or G₇×G₆ genotype for the consumption of green fruits and G₂×G₅ genotype for short durated ripen fruits might be suggested for further selection in next generation that would be effective in future for breeding program.

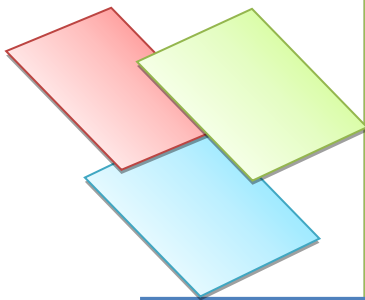

INTRODUCTION



CHAPTER I

INTRODUCTION

Tomato (*Solanum lycopersicum* L.) is one of the most essential vegetable crops all over the world. It belongs to the family Solanaceae and its chromosome number is $2n=2x=24$ (Jenkins, 1948). It is sexually propagated crop plant which flower is bisexual and contains four to eight (4-8) flowers in each compound inflorescence. Tomato is herbaceous, warm season, annual to perennial and self-pollinated crop. Though it is a self-pollinated crop, a certain percent of cross-pollination also occurs. It is a day neutral plant that grows under a wide range of soil and climatic conditions all over the world. Tomato is the third most produced vegetables among the world after potato but at top position in the list of processed vegetables (FAO, 2019). Tomato is grown throughout the whole world because of its wider adaptability, high yielding potentiality, and suitability and for its wider uses in fresh as well as processed food industries (FAOSTAT, 2019).

Tomato is an exogenous crop in Bangladesh. It was originated from Peru, Ecuador region (Rick, 1969). The native of tomato is the new world (The America) i.e., the Andean region which includes parts of Bolivia, Colombia, Chili, Ecuador and Peru. Tomato gradually spread from its native land to European countries and rest of the world (Heisar, 1969). All the species of tomato are native to Western South and Central America (Rick, 1976). Wild cultivars of tomato were found in the tropical rain forests of South America. Tomato is grown in almost all countries around the world except the colder regions at present (Hannan *et al.*, 2007).

The world dedicated 4,648,384 hectares cultivable land in 2019 for tomato cultivation and the total production was about 184,301,395 metric tons (FAO, 2019). In Bangladesh, at present 8.95% of the cultivable land area (69,697 acres) was under tomato cultivation both in winter and summer season and the total production was about 387,653 metric tons (BBS, 2019). The suitable tomato growing areas in Bangladesh are Dhaka (29,250 $\text{mt}\cdot\text{ha}^{-1}$), Rajshahi (94,205 $\text{mt}\cdot\text{ha}^{-1}$), Rangpur (76,175 $\text{mt}\cdot\text{ha}^{-1}$), Barisal (7,221 $\text{mt}\cdot\text{ha}^{-1}$), Chattogram (62,515 $\text{mt}\cdot\text{ha}^{-1}$), Mymensing (37,403 $\text{mt}\cdot\text{ha}^{-1}$), Khulna (32,640 $\text{mt}\cdot\text{ha}^{-1}$) and Shylhet (28,224 $\text{mt}\cdot\text{ha}^{-1}$). The highest tomato production area was Rajshahi and Rangpur

(BBS, 2019). Now-a-days tomato becomes very popular for consumer's health benefits, for farmer life due to its high market value as well as for researcher due to its genetics and genomic characters (Akhter, 2021). Tomato is a delicious vegetable that used in salad, soups and processes into stable products like ketchup, sauce, pickles paste, chutney and juice. Tomato is an important source of vitamin A, B, C and other elements. More than 7% of total vitamin-C of vegetable comes from tomato in Bangladesh (Dhaliwal *et al.*, 2013). It contains 94 gram water, 0.5 g minerals, 0.8 g fiber, 0.9 g protein, 0.2 g fat and 3.6 g carbohydrate and 356 mg carotene in 100 g edible ripen tomato (Anonymous, 2010). In many countries, it is considered as "poor man's orange" because of its improved nutritional values (Saleem *et al.*, 2013). Tomato is very much rich in antioxidant called Lycopene. Lycopene is a powerful antioxidant that reduces the risk of prostate cancer (Khapte and Jansirani, 2014).

It is important to study the genetic variability of tomato as variability assessment among tomato genotypes that helps to maintain and utilize germplasm resources to meet the increasing demand of tomato and for the further improvement of the cultivars (Reddy *et al.*, 2013). Genetic variability is the material from which superior genotypes can be evolved just after selection. Higher the amount of variability in the population, higher is the scope for improvement of yield through selection. Selection with particular objectives in F₂ generation is very much effective and selfing of those selected genotypes generation after generation helps to develop inbred lines (similar to the parental lines of the exotic hybrids). These inbreeds with desired characters including high yield potentiality can be used as High Yielding Variety (HYV) as well as the parents for hybrid variety.

In breeding program, it is essential to have information about the heritability for the selection of superior genotypes (Nechifor *et al.*, 2011). Heritability is the variation which is transferred from parents to their offspring. Not only high heritability alone is enough to make efficient selection in segregating generation but also needs a substantial amount of genetic advance (Narolia *et al.*, 2012). Improvement in the performance of selected lines over the original population is called the genetics advance. The influence of environment on characters can be determined by heritability and genetic advance only after selection (Mohamed *et al.*, 2012). Yield is the main objective of a crop breeding program, so it is

essential to have the knowledge of association among various characters which contribute to the yield (Osei *et al.*, 2014). The character association can be indicated by the correlation coefficients.

In a breeding program, correlation coefficient has always been a helpful instrument for the selection of desirable characters. Correlation coefficient analysis measures the mutual relationship between various characters. The component characters can be determined through selection for yield improvement. Correlation coefficient is not enough to anticipate traits interrelationship leading to yield. In these circumstances, path coefficient analysis acts as an additional informative tool (Islam and Khan, 1991; Singh *et al.*, 1989). Path analysis divides the correlation coefficients into direct and indirect effects of a set of dependent variables on the independent variables that help in selecting elite genotypes.

This investigation was therefore undertaken to study the genetic variability and character association among 39 diverse tomato genotypes on 20 characters for yield and quality attributes. With this information, this investigation was carried out with objectives to estimate the genetic component of variation, heritability, genetic advance and trait association among yield and yield traits as well as among quality parameters. Research is an organized investigation of a problem in which there is an attempt to gain a solution to a problem. To get right solution of a right problem, clearly defined objectives are very important. The following objectives were undertaken to achieve the expected goals:

- To study the genetic variability among tomato genotypes of F₂ generation;
- To know the nature of association between fruit yield and its components by estimating genotypic and phenotypic correlation coefficient; and
- To know the direct and indirect effects between yield and yield contributing characters through path coefficient analysis.

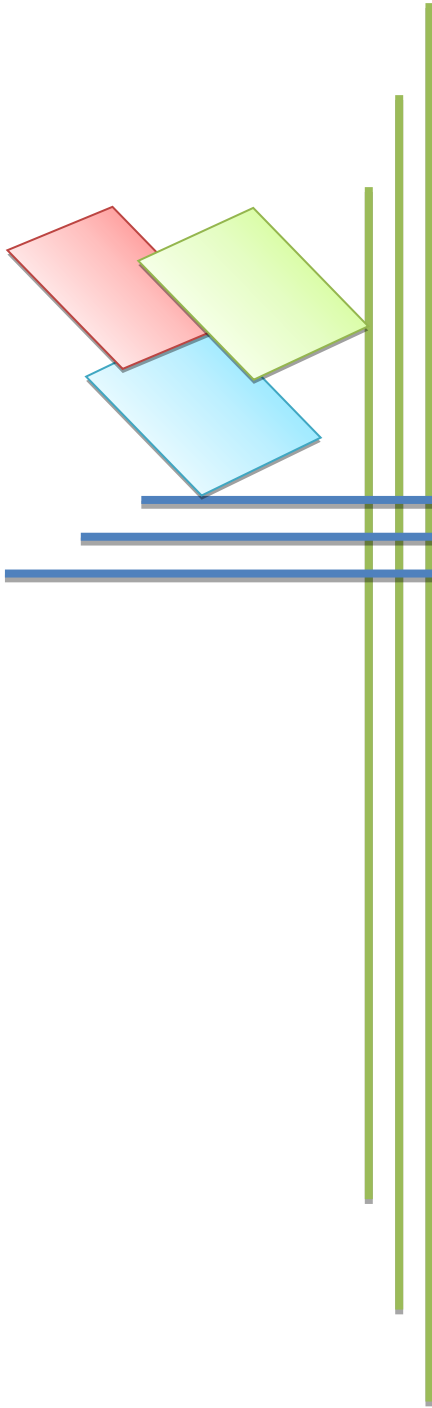

***REVIEW OF
LITERATURE***



CHAPTER II

REVIEW OF LITERATURE

Tomato is one of the most important vegetable crops in Bangladesh and received much attention to the researchers throughout the world. The tomato is an autogamous species which has woody stem. Tomato is a well-studied crop species for breeding, genetics, and genomics in plants. Effect of genotypes has different modifying influences on growth, yield and yield contributing characters of winter tomato. The planning of a breeding program for improvement of any crop considering any specific traits requires information on the genetic variability and nature present in the available breeding materials and association among different agro-morphogenic and nutritional traits. Keeping in view the objectives of the present investigation, the review of literature concerning to the studies conducted for this dissertation is outlined under the following headings:

2.1 Tomato

The tomato is the edible berry of the plant *Solanum lycopersicum*, commonly known as a tomato plant. The species originated in western South America and Central America. Its domestication and use as a cultivated food may have originated with the indigenous peoples of Mexico. Tomato plants typically grow to 3-10 feet in height. They are vines that have a weak stem that sprawls and typically needs support. Indeterminate tomato plants are perennials in their native habitat, but are cultivated as annuals. The nomenclatures, origin, distribution, nutritional and medicinal values of tomato are reviewed in this section.

2.1.1 Nomenclature, Origin and distribution of tomato

Well known scientific name of tomato for most of the scientific community is *Solanum lycopersicum* L. the old scientific name of the tomato was *Lycopersicon esculentum* Mill. The English word “tomato” comes from the Spanish word, *tomate*, which in turn comes from the Nahuatl (Aztec language) word *tomatōtl*. It first appeared in print in 1595. In 2005, Spooner and his associates proposed a change back to the original nomenclature used by Linnaeus in 1753 (Anonymous, 2015). According to “International Plant Name Index” in 1753, Linnaeus placed the tomato in the genus *Solanum* as *Solanum*

lycopersicum (Anonymous, 2014). According to “International Plant Name Index” and “Slow Food ® Upstate”, in 1753, Linnaeus placed the tomato in the genus *Solanum* as *Solanum lycopersicum* and in 1768 Philip Miller moved it to its own genus, naming it *Lycopersicon esculentum*. This name came into wide use, but was in violating of the plant naming rules. Genetic evidence has now shown that Linnaeus was correct to put the tomato in the genus *Solanum*, making *Solanum lycopersicum* the correct name (Natural History Museum; Peralta and Spoonar, 2001). Both names, however, will probably be found in the literature for some time. Tomato translates to “*wolfpeach*” peach because it was round and luscious and wolf because it was erroneously considered poisonous (Fillipone, 2014).

Tomato originated from south part of America which includes Peru, Bolivia, Chile and Ecuador, where they usually grew wild. Aztecs and Incas were first cultivated tomatoes about 700AD. Tomatoes didn’t arrive in Europe until 16th century although it is not known how. It has been said that Spanish Conquistadors brought back tomato in Europe from America. The tomato is native to western South America and Central America (Filippone, 2014).

Tomato is a tropical plant and grown in almost every corner of the world. Mexico has been considered the most likely center of domestication of tomato. Italy and Spain are considered secondary centers of diversification (Gentilcore, 2010; Smith, 1994). The cultivated tomato originated in the Peru-Ecuador-Bolivia area of the South American (Vavilov, 1951). Major tomato producing countries are Spain, Brazil, Iran, Mexico, Greece, Russia, China, USA, India, Turkey, Egypt and Italy. The introduction of the species in Europe, from Mexico, was pivotal in the reduction of genetic variability, since in the European habitat tomatoes were generally cultivated in protected environments.

2.1.2 Nutritional and medicinal value of tomato

Tomato is most popular as salad in the raw state and is made into soups, juice, ketchup, pickles, sauces, conserves, puree, paste, powder and other products (Akhter, 2021; Nahar and Ullah, 2011). It is highly nutritious and rich source of health building substances particularly vitamins and minerals. Vitamin C, total soluble solids (TSS) and acid

contents are commonly considered as fruit quality determining properties in tomato. Vitamin C is a principal nutrient of tomato fruit. More than 7% of total vitamin-C of vegetable origin comes from tomato in Bangladesh. It contains 94 g water, 6 g minerals, fiber, protein, fat and carbohydrate. It also contains other elements like 48 mg calcium, 0.4 mg iron, 356 mg carotene, 0.12 mg vitamin B1; 0.06 mg vitamin B2 and 27 mg vitamin C in each 100 g edible ripen tomato (BARI, 2010). Vitamins are highly significant from the nutritional point of view. Soluble solids include mainly the sugars such as glucose, fructose and sucrose. The tomato's medicinal properties had already been endorsed in Continental Europe in the 16th Century and their consumption was believed to benefit the heart among other things, as it contains lycopene, one of the most powerful natural antioxidants which, especially when cooked, have been found to help prevent prostate, lung, stomach, pancreatic, colorectal, esophageal, oral, breast and cervical cancers. Lycopene's, bioflavonoid closely related to beta carotene, are potent antioxidants present in tomatoes and seem to be responsible for these natural cancer-fighting properties (Anonymous, 2016).

2.2 Variability

The success of any crop improvement program depends on the presence of genetic variability and the extent to which the desirable trait is heritable. Genetic diversity can be estimated using both morphological and molecular markers. The presence of genetic variability in the breeding material has been emphasized by previous researchers (Akhter, 2021; Naz *et al.*, 2013 and Reddy *et al.*, 2013). Some of the previous research reports are discussed here:

Bhuiyan (2014) conducted an experiment on 18 genotypes to analyze genetic variability and stated that the number of fruit yield per plant showed highest range of variation with the highest mean value. In case of days to maturity, plant height, number of cluster per plant, number of fruits per cluster, number of fruits per plant and yield per plant showed higher influence of environment for the expression of these characters. Similarly, Paul *et al.* (2014) found significant differences among genotypes while working with the genetic variability among the yield contributing traits and their direct and indirect contribution of these parameters towards the yields and identify better combination as selection criteria

for developing high yielding tomato genotypes. Again, Naz *et al.* (2013) conducted a field experiment on the basis of two parameters such as morphological and molecular parameters to study the genetic variation among twenty five tomato accessions that helped in the reliable varietal selection for breeding program. This study revealed that height of plant, fruit color and fruit size show variability.

Reddy *et al.* (2013) revealed considerable genetic variability for all the eighteen quantitative characters which was pertaining to the growth, earliness, yield and quality. Fruit weight, plant height and number of fruits per plant contributed to the total variation. Characterization and analysis of genetic affinity among the tomato varieties are necessary before setting any program for their improvement. Moreover, several private commercial companies released various tomato varieties with different trade names. Due to non-availability of the sources and parents of these varieties a lot of confusions are created regarding the authenticity of this tomato germless. To prevent trade piracy, BARI released varieties and other commercially available varieties need to be judged on the basis of their genomic information (Alam *et al.*, 2012).

An experiment was carried out by Shashikanth *et al.* (2010) to study the genetic variation among 30 tomato germplasm lines and observed that the range of variation and mean values were high for plant height, days to 50% flowering and average fruit weight. He also observed that high genotypic variance was for most of the characters indicating a high contribution of the genetic component for the total variation. Morphological trait measurements can provide a simple technique of quantifying genetic variation and simultaneously assessing genotype performance under relevant growing environments (Shuaib *et al.*, 2007). Similarly, Mahesha *et al.* (2006) conducted an experiment to study genetic variability in 30 genotypes of tomato revealed significant difference for all the characters under study and observed a wide range of variation for plant height, number of branches per plant, fruit weight, fruit length, fruit diameter, number of locules per fruit, fruit set percentage, fruits per plant, fruit yield per plant, ascorbic acid content and total soluble solids. Again, Singh *et al.* (2005) conducted a field experiment on 15-advance generation breeding lines of tomato, to study the variation for total soluble solids (TSS), pericarp thickness, fruit firmness, pH, lycopene content and dry matter content and

observed significant differences among the genotypes under normal conditions, whereas differences were not significant under high-temperature conditions. The population means were higher during November than February planting for all the characters except acid content and TSS. In another experiment, Agong *et al.* (2001) also showed a large and significant variation in the quantitative traits between the accessions. The average fresh and dry fruit weight varied notably among the accessions. Most of the landraces gave lower fresh and dry fruit yields than the market cultivars.

2.2.1 Days to first flowering

An experiment was also carried out by Farzaneh *et al.* (2013). She and her associates showed earliness in number of days to first flowering while studying combining ability from a 9x9 di-allele cross. Whereas Monamodi *et al.* (2013) had not found any significant differences in days to first flowering among tomato genotypes. Similarly, Barone *et al.* (2008) observed that a minimum of 66 days was necessary for first flowering for cv. Selectim-7 and a maximum of 83 days for cv. Mtuatham in an experiment with 18 promising cultivars of tomato considering local cultivar Patharkutchi as control at Mymensingh. Again, Kumari *et al.* (2007) recorded data for total soluble solids, dry matter content, reducing sugars, titratable acidity, ascorbic acid, lycopene, days to flowering, days to maturity, number of fruits per bunch, weight per fruit, fruit length, fruit width, number of fruit bearing branches, total number of fruits per plant, plant height, early yield and total yield and found that there were highly significant differences for all the characters among parents except acidity, early yield, total yield, and days to flowering.

An experiment was conducted by Singh *et al.* (1993) on heterosis breeding in tomato eight cultivars with diverse values for quantitative characters were crossed in a diallel set. Data on yield and nine component traits were recorded for the 28 F1 hybrids and parents. Hybrids Punjab Chuhara × 84-8, HS102 × Pusa Ruby, HS102 × 84-8 and Pusa Ruby × 84-10 showed significant negative heterosis for days to first flowering over the better parent, indicating their potential for producing an early crop. Hybrid Punjab Chuhara × 84-8 showed the highest heterosis for fruit yield plant-1 (1200 g).

2.2.2 Plant height

Naime (2016) conducted an experiment on fifteen genotypes of tomato to analyze their diversity and she revealed that plant height showed higher influence of environment for the expression of this character. Similarly, Naz *et al.* (2013) used 25 tomato germplasm to characterize morphologically by comparing the height of plant, leaf length, shape and arrangement, fruit shape and size. This study revealed that height of plant show highest variability. Again, Hannan *et al.* (2007) conducted an experiment, to estimate heterosis and character association in 45 single cross hybrids, obtained from 10 parental lines of tomato for yield and yield component traits. The characters studied were plant height, days to first flowering (DFF), number of flowers per cluster (NFPC), number of fruits per plant (NFPP), fruit weight per plant (FWPP) and days to first fruit ripening. They obtained significant differences among genotypes for all the traits and found positive high significant hererosis for FPP (72.9, 75.33 and 20.74), TFWPP (189, 172 and 187), NFPC (48.65, 44.14 and 37.86) over the mid parent, better parent and standard parent heterosis, respectively, and significantly high percentage of positive heterosis for NFPP, TFWPP and NFC. They concluded that five hybrids possessed significant positive useful heterobeltiosis for TFWPP, positively correlated with FPP, NFPC and Plant height.

A field experiment was conducted by Joshi *et al.* (2004) with forty tomato genotypes to evaluate their genetic variability and noticed that plant height gave the highest heritability (78.82%). Similarly, Parthasarathy and Aswath (2002) conducted a study with 23 genotypes of tomato and observed a considerable variability among genotypes for 8 morphological characters. Plant height, fruit number, fruit size were contribute higher variability among them. Again, Matin and Kuddus (2001) also reported that phenotypic variance was relatively higher than genotypic variance for plant height. They again observed that genotypic co-efficient of variation was lowering than phenotypic co-efficient of variation indicating influence of environment for expression of this character. Another experiment was carried out by Aditya *et al.* (1995) and Matin *et al.* (2001). He and his associates also reported that phenotypic variance was relatively higher than genotypic variance for this trait that indicating the influence of environment for the expression of this character.

Dev *et al.* (1994) observed heterosis in tomato in a line \times tester analysis. Appreciable heterosis was observed for the nine characters studied over their respective better parent. Heterosis over the better parent ranged from 0.05 to 115.7%, the minimum being for plant height and the maximum for number of fruits per plant. They concluded that the best F₁ hybrid was EC156 \times Marglove, which gave 83.18 and 29.23% greater yields than the better parent and the control variety, respectively. Plant height has been found to vary from variety to variety and also among different groups such as determinate, indeterminate type. In an experiment with 20 varieties of tomato in Ghana Nsowah (1970) and Norman (1974) observed significant differences between cultivars for plant height.

2.2.3 Days to Maturity

An experiment was carried out by Saleem *et al.* (2013) with twenty-five F₁ hybrids that generated from 5 \times 5 diallel crosses and found moderate heritability for days to maturity indicated the favorable influence of environment rather than genotypes consequently, selection of superior genotypes to develop early maturing genotypes would not be rewarding in early generations. Similarly, Pradeep kumar *et al.* (2001) conducted an experiment to quantify genetic variation in tomato for yield and resistance to Bacterial Wilt based on the idea that proper and systematic evaluation of genetic resources was essential to understand and estimate the genetic variability, heritability, and genetic advance. Data were recorded on plant height, days to maturity, number of fruits plant⁻¹, pericarp thickness, locule number, total soluble solids, average fruit weight, number of fruit plant⁻¹ and plant yield. They observed highly significant differences among the genotypes for all the traits as well as the high genotypic coefficient of variation for all the characters. Higher heritability estimates and high genetic advance for all the characters indicated the lesser influence of environment and higher role of additive gene action, respectively, so they suggested selection for rewarding improvement of these traits.

2.2.4 Number of branches per plant

Singh *et al.* (2005) conducted a field experiment with 30 tomato and five genotypes (DT-39, RHR-33-1, ATL-16, DARL-13 and RT-JOB-21) showed higher number of primary

branches than the control. The maximum number of fruits per plant was obtained from BT-117-5-3-1. Fruit yield was maximum (1.84 kg/plant) in DT-39. Most of the cultivars showed higher total soluble solids content in their fruits compared to the control. The acidity percentage in fruits was highest in KS-60. The physiological loss in weight at 7 days was highest in NDT-111 and lowest in Plant T-3. ATL- 13 showed the highest lycopene content (59.67 mg/100 g). Similarly, Upadhyay *et al.* (2005) evaluated 34 genotypes of tomato and observed a range between 2.33-7.0 branches per plant. He reported the PCV (35.93%) was higher than GCV (24.72%) for this character. Again, Shraavan *et al.* (2004) conducted an experiment with 30 tomato genotypes to study their genetic variability and reported significant difference for number of primary branches per plant among the genotypes.

Singh *et al.* (2002) carried out a field experiment with 92 tomato genotypes to study genetic variability and reported that the analysis of variance revealed highly significant genetic variation for plant height, number of days to first fruit set, number of fruit clusters per plant, number of fruits per plant, fruit weight per plant and fruit yield. The traits characterized by adequate variability may be considered in a hybridization program for yield improvement in tomato. In another case, Singh and Singh (1993) conducted an experiment on heterosis breeding in tomato. Eight cultivars with diverse values for quantitative characters were crossed in a diallel set. Data on yield and nine component traits were recorded for the 28 F1 hybrids and parents. Hybrid Punjab Chhuhara × 84-8 showed the highest heterosis for fruit yield plant-1 (1200 g). Heterosis for this hybrid was also superior for number of fruits plant -1 and early yield over the mean parent, and number of branches plant -1 over the better parent.

2.2.5 Number of clusters per plant

Dufera (2013) conducted an experiment using twenty one tomato germplasms. Higher genotypic and phenotypic coefficients variation values were recorded by the character fruit clusters per plant, indicating the presence of variability among the genotypes and the scope to improve these characters through selection. In another case, Singh *et al.* (2002) studied variability of 92 genotypes of tomato with regards to number of fruit clusters per

plant in India during winter Season 2000-2001. They reported that the high genotypic and phenotypic variation was found for number of fruit clusters per plant.

2.2.6 Number of fruits per cluster

Samadia *et al.* (2006) evaluated 14 cultivars of tomato and reported almost similar estimates of PCV and GCV for this character. In contrast, Arun *et al.* (2003) evaluated 37 genotypes of tomato and observed the PCV was higher than GCV for Number of fruits per cluster. Similarly, Singh *et al.* (1997) derived information on genetic variability, heritability and yield correlations from data on 14 agronomic and yield-lated traits in 23 genotypes of tomato. They concluded that based on heritability and genetic advance values, effective selection may be made for fruit weight and number of fruits per plant as fruit yield showed strong positive correlation with number of fruits per plant and number of fruits per cluster. They recommended that number of fruits per plant and numbers of fruit per cluster are the most important character for consideration in a selection programme for improvement of yield.

2.2.7 Number of fruits per plant

According to Buckseth *et al.* (2012) high GCV obtained for average fruit weight, yield per plant, pericarp thickness, and number of seeds per fruit. Seventeen diverse genotypes of tomato were evaluated by Thakur (2009) for their performance and interaction with changing environments through the characters like fruit yield, number of fruits/plant. The analysis of variance indicated highly significant differences between the genotypes and environments for all the characters studied. Similarly, Saeed *et al.* (2007) observed the variation among the accessions. The coefficient of variation was greater in traits such as number of fruits per plant followed by number of flowers per plant and yield per plant. Again, Joshi *et al.* (2004) conducted a held experiment with forty tomato genotypes to evaluate their genetic variability and observed the number of fruits per plant gave the highest phenotypic and genotypic coefficient of variation (61.21 and 44.05, respectively) and genetic advance as percentage of mean (65.24). Mohanty *et al.* (2003) observed that the number of fruits per plant had positive direct effects on the yield and negative indirect effects on average fruit weight.

Brar *et al.* (2000) estimated phenotypic and genotypic co-efficient of variation and observed high variability in the characters of number of fruits per plant of 186 genotypes of tomatoes. In another case, Bhutani *et al.* (1989) performed a varietal trial of 84 genotypes and reported that Set-23, (Growthens Globe, Punjab Chhuhara, VSII-2. Pusa Red Plum and HS 102 were the best for number of fruits per plant. Maximum genetic improvement would be possible by genetic variability for number of fruits suggested by Sidhu and Singh (1989) from their observation. Similarly, Sharma and Rastogi (1993) studied variability of seven characters in tomato and observed significant variation for number of fruits per plant. They also reported high genotypic coefficient of variation for number of fruits per plant. Again, Reddy and Reddy (1992) evaluated 139 tomato genotypes and estimated phenotypic and genotypic variances, phenotypic and genotypic co-coefficients of variation. Considerable variation was observed for a number of fruits per plant (4.0-296.5).

2.2.8 Fruit length

Chishti *et al.* (2008) conducted a study on the analysis of combining ability for yield, yield components and quality characters in tomato (*Lycopersicon esculentum* Mill.), on plant material comprising 12 parental lines and their F₁ hybrids (direct crosses). They recorded data on days to flowering, number of flowers per cluster, number of fruits per cluster, number of marketable fruits per plant, fruit length, fruit width, and fruit weight, fruit yield per plant, pericarp thickness, and fruit firmness at red stage, total soluble solids and pH of juice. Analysis of variance revealed highly significant differences among genotypes, parents and hybrids, as well as highly significant mean squares due to GCA and SCA for all the characters. Similarly, Agong *et al.* (2001) conducted research on the genotypic variation of 35 Kenyan tomatoes (*Lycopersicon esculentum* Mill.) germplasm, to examine the variation in tomato germplasm based on the morphological, agronomic and biochemical traits with an ultimate view of identifying potential accessions to improve tomato production. They found a large and significant variation in quantitative traits between the accessions largely attributable to the genotypic variability within and between the individual tomato groups and suggested that genetic improvement of tomato should not only depend on the introduction but also on the gradual development of more

closely adapted accessions suited to local conditions. They also suggested that fruit number plant⁻¹ and fruit index (length/width) can be used to create a better understanding of diversity in the tomato for yield and crop improvement.

2.2.9 Fruit diameter

According to Saleem *et al.* (2013) twenty-five F₁ hybrids generated from 5×5 diallele crosses were evaluated to study the quantitative genetics of yield and some yield related traits. The highest estimates of genotypic and phenotypic coefficients of variability were recorded for number of fruits per plant while fruit width was the most heritable trait. Similarly, Kumari *et al.* (2007) recorded data for fruit width and found that there were highly significant differences among parents. Again, Anupam *et al.* (2002) evaluated 30 genotypes of tomato and found similar results for this character.

2.2.10 Fruit weight

Farzaneh *et al.* (2013) conducted a study and found significant variation due to general combining ability (GCA) as well as specific combining ability (SCA) indicated the importance of additive and non-additive types of gene action in inheritance of all characters except number of fruits per plants. Similarly, Shravan *et al.* (2004) studied genetic variability with 30 tomato genotypes in Uttar Pradesh of India and reported significant difference for average fruit weight among the genotypes. Mohanty *et al.* (2003) carried out in a field experiment to study genetic variability of 18 tomato cultivars and observed that the average fruit weight had positive direct effects on the yield and negative indirect effects on number of fruits per plant. Again, Singh *et al.* (2002) carried out a field experiment to study genetic variability of fifteen heat tolerant tomato and showed that phenotypic (PCV) and genetic (GCV) coefficients of variation were high for average fruit weight.

Padmini and Vadivel (1997) performed an experiment to study genetic variability of six F₂ crosses and their parental cultivars and reported that progeny of cross In Memory 5.30 p. m. X PKM-1 produced the highest mean values for individual. They also reported that fruit weight small difference was observed between genotypic and phenotypic variance for individual fruit weight. In another case, Sahu and Mishra (1995) reported that fruit

weight had a high genotypic coefficient of variation in 16 lines of tomato. Considerable variation was observed for average individual fruit weight. Similarly, Pujari *et al.* (1995) studied variability for 8 yield component characters of tomato and observed high genotypic and phenotypic co-efficient of variation for average fruit weight.

Aditya (1995) reported that analysis of variances showed highly significant mean squares due to variety for average fruit weight among the 44 varieties of tomato. Genotypic variance associated with a genotypic coefficient of variation was smaller than a phenotypic variance and phenotypic coefficient of variation respectively. Similarly, Reddy and Reddy (1992) estimated phenotypic and genotypic variances, phenotypic and genotypic co-efficient of variation for individual fruit weight. Considerable variation was observed for average individual fruit weight. Again, Ahmed (1987) reported that a wide range of variation was observed for individual & unit weight among 4 genotypes of tomato. He also reported that genotypic co-efficient of variation was very high for individual fruit weight in four tomato varieties namely EC32099, HS102, HS107 and Columbia respectively.

2.2.11 Yield per plant

Singh (2009) assessed 48 genotypes for their genetic divergence using Mahalar statistics. They observed that clustering pattern indicated no difference between geographical distribution of genotypes and genetic divergence. They concluded that characters like number of fruits plant⁻¹, average fruit weight, plant height and fruit yield contributed maximum to genetic divergence. In another experiment, Singh *et al.* (2006) observed considerable range of genetic variability for yield, yield components and biochemical characters in the materials under study and maximum genotypic coefficient of variation was recorded for number of leaves per plant, followed by number of clusters per plant. Similarly, Sachan (2001) performed an experiment with certain tomato genotypes and he also reported significant differences among the genotypes for yield per plant. Matin and Kuddus (2001) reported significant differences for yield per plant among the genotypes tested. He also reported that phenotypic variance was little higher than genotypic variance indicating slight environmental influence on this trait. Again, Pujari *et al.* (1995) and Ghosh *et al.* (1995) observed the highest variation in yield per plant.

Aditya *et al.* (1995) observed highly significant differences for average yield per plant among 44 genotypes of tomato. She also reported that phenotypic variance and phenotypic coefficient of variation were higher than a genotypic variance and genotypic coefficient of variation respectively. Similarly, Hossain *et al.* (1973) reported that Roma V.F. was the highest yielding among the 8 long fruited tomato varieties grown in 3 seasons at Lyallpur with an average yield of 22.10 t/ha and T-43 was the best among the 9 large fruited varieties with an average yield of 22.11 t/ha.

2.3 Heritability and genetic advance

Heritability and genetic advance are the most important parameters to judge the breeding potentiality of a population for future development through selection. Selection of plants on phenotypic characteristics is the most important task for all plant breeding practices. The effectiveness of selection for yield depends upon heritability. Many researchers have studied heritability and genetic advance of yield and many yield contributing characters of tomato. The literatures very relevant to the present study are reviewed below:

Naime (2016) found all the characters of her study such as plant height, number of branches per plant, number of flowers per plant, number of fruits per plant etc. exhibited the highest value of heritability. In another experiment, Akhter (2021) revealed high heritability along with high genetic advance as percent of mean in plant height, individual fruit weight and fruit yield per plant during her working with 28 tomato genotypes to study diversity. Similarly, Paul *et al.* (2014) found in an experiment that the genotypic coefficient of variation (GCV) and phenotypic coefficient of variation (PCV) were high for days to germination, fruits per branch, harvest index and yield per plant of tomato. All characters were highly heritable in broad sense.

According to Saleem *et al.* (2013), a study of quantitative genetics of yield and some yield related traits. The highest estimates of genotypic and phenotypic coefficients of variability (GCV and PCV) were recorded for number of fruits per plant while fruit width was the most heritable trait. Similarly, Narolia (2012) thirteen quantitative characters were studied in 55 genotypes of tomato. High heritability coupled with high genetic advance as per cent of mean was observed for all the characters except days to 50%

flowering indicating the presence of additive gene action in the expression of these characters. Again, Buckseth *et al.* (2012) found high heritability with high genetic advance for number of fruits per plant, average fruit weight, and yield per plant and pericarp thickness indicating that most likely the heritability is due to additive gene effects and selection may be effective. In another case, Shashikanth *et al.* (2010) observed the range of variation and mean values were high for plant height, days to 50% flowering and average fruit weight. He also observed high genotypic variance for most of the characters indicating a high contribution of the genetic component for the total variation. Again, Ponnusviamy *et al.* (2010) evaluated 12 varieties of tomato to estimate heritability and reported that high heritability coupled with high genetic advance as percentage of mean for average fruit weight, indicating the control of such character by additive gene. He also recorded that high heritability coupled with low genetic advance as percentage of mean for rest of the characters except pericarp thickness, indicating most of the characters were governed by non-additive genetic components.

In another experiment, Pandit *et al.* (2010) evaluated 12 varieties of tomato to estimate heritability and reported that high heritability coupled with high genetic advance as percentage of mean for average fruit weight, indicating the control of such character by additive gene. He also recorded that high heritability coupled with low genetic advance as percentage of mean for rest of the characters except pericarp thickness, indicating most of the characters were governed by non-additive genetic components. Similarly, Saeed *et al.* (2007) observed that broad sense heritability was highest for number of fruits per plant (96.56%), followed by number of flowers per plant (93.45%), reflecting the effectiveness of selection in the present germplasm of tomato improvement. Again, Padda *et al.* (2007) observed that broad sense heritability was highest for number of fruits per plant (96.56%), followed by number of flowers per plant (93.45%), reflecting the effectiveness of selection in the present germplasm of tomato improvement. Golani *et al.* (2007) also evaluated 20 tomato genotypes and observed high heritability with high genotypic coefficient of variation and genetic gain for 10-fruit weight, number of locules per fruit and fruit yield, which could be improved by simple selection. Kumari *et al.* (2007) also reported that the estimates of heritability were high for all the characteristics and genetic advance was high for plant height, moderate for total number of fruit bearing branches,

weight per fruit and days to maturity, while the remaining characteristics had low values of genetic advance. Again, Mahesh *et al.* (2006) estimated heritability and expected genetic advance in 30 genotypes of tomato and observed that fruit weight, fruits per plant and plant height exhibited very high heritability values along with high genetic gain. It indicated the importance of considerable additive gene effects and therefore greater emphasis should be given on these characters while selecting the better genotypes in tomato.

Singh *et al.* (2006) estimated heritability for nineteen genotypes of tomato and observed high heritability for ascorbic acid content, average weight of fruits, number of leaves per plant, number of locules per fruit, number of fruits per plant, leaf area and dry matter content. High estimates of heritability with high genetic advance was recorded in case of number of leaves per plant, average weight of fruits, number of fruits per plant and plant height, whereas high heritability with low genetic advance was recorded for number of locules per fruit, dry matter content, pericarp thickness and yield per plant. Similarly, Joshi *et al.* (2004) observed moderate heritability and moderate genetic gain for number of fruits per cluster, fruit length, fruit breadth, stem end scar size, number of locules per fruit, whole fruit firmness, ascorbic acid content and plant height indicating additive gene effects. Moderate heritability and low genetic gain for harvest duration suggests the presence of dominance and epistatic effects.

In another case, Hanson *et al.* (2002) proposed heritability as the ratio of genotypic variance to the total variance in a non-segregating population. Since, the estimate of heritability gives indication of the amount of progress expected from selection, as they are most meaningful when accompanied by estimate of genetic advance. Genetic advance is the measure of improvement that can be achieved by practicing selection in a population. Similarly, Brar *et al.* (2000) reported that the number of fruits per plant, total yield per plant and marketable yield per plant had low to moderate estimates of heritability and genetic advance and number of marketable fruits per plant had high values of heritability and genetic advance. Again, Nessa *et al.* (2000) reported high heritability for number fruits per plant, plant height and moderate heritability for yield per plant. Mittal *et al.* (1996) also estimated heritability and genetic advance in 27 genotypes

of tomato. High heritability associated with high genetic advance was observed by them indicating the character, predominantly under the control of additive gene, could be improved through selection. In another experiment, Aditya (1995) reported high heritability (in broad sense) with high genetic advance in percentage of mean for number of fruits per plant, individual fruit weight and plant height. However, yield per plant showed moderate heritability and low genetic advance but highest genetic advance as percentage of mean under selection.

2.4 Correlation co-efficient analysis between yield and yield contributing characters

Correlation analysis in tomato revealed that the percent fruit set, average fruit weight, number of primary branches and number of fruit per plant were positively and significantly associated with yield per plant. Correlation between the characters is an estimate to evaluate the inter-relationships between the characters which will help the breeders to choose selection techniques. In most cases correlation between yield and yield contributing characters was studied as increased yield is one of the main targets of most of the breeders. Fruit yield of tomato is the final character which is contributed by a complex chain of interrelating effects of different yield contributing characters. Many authors have studied correlation between yield and yield contributing characters of tomato. Some pertinent recent literatures are reviewed in this section:

Akhter (2021) consisting fifteen genotypes of tomato to study genetic diversity and a significant positive correlation with yield per plant was found in number of branches per plant, number of flowers per plant, number of fruits per plant, single fresh fruit weight at genotypic and phenotypic level while a significant negative correlation was found in the number of fruits per cluster at genotypic and phenotypic level. Similarly, Nur-unnahar (2015) conducted an experiment on 28 tomato genotypes to study character association and found significant positive correlation positive direct effect in plant height, number of primary and secondary branches per plant, average fruit weight and width of fruit. Correlation analysis in tomato revealed that per cent fruit set, number of primary branches, number of fruits per plant, average fruit weight, total soluble solids, fruit

length, fruit firmness, number of flower trusses per plant and pericarp thickness were positively and significantly associated with yield per plant (Khapte and Jansirani, 2014).

According to Monamodi *et al.* (2013) there was a strong positive significant correlation between numbers of branches per plant with fruit number per plant. This was because the more the branch number in a plant, such plant will produce more fruits in a plant. Similarly, Mahapatra *et al.* (2013) found fruit yield had a positive and significant correlation with plant height, number of primary branches per plant, number of flower clusters per plant, number of fruits per plant, fruit length, fruit width, and average fruit weight. It was observed that with an increase in plant height, there was a corresponding increase in a number of primary branches per plant, days to 50% flowering and number of flower clusters per plant. The experiment carried out by Buckseth *et al.* (2012) consisting of 40 genotypes of tomato to study the correlation among different quantitative and qualitative traits in tomato genotypes. The study revealed highly significant differences among the genotypes for all the characters studied.

Kumar *et al.* (2011) studied correlation coefficient analysis for thirty diverse tomato genotypes and noticed that correlation coefficients at the genotypic level were generally higher than the corresponding phenotypic ones and yield per plant was positively and significantly associated with plant height, fruit number per plant, fruit shape index and pericarp thickness. Similarly, Ya Dong *et al.* (2010) showed that the lycopene content is very significantly positively correlated with single inflorescence flower numbers, single inflorescence fruit numbers and soluble solids content, but very significantly negatively correlated with pedicel length and single fruit weight. He also reported that the lycopene content is significantly positively correlated with fruit shape index, but significantly negatively correlated with fruit firmness, flesh thickness, longitudinal diameter fruit. Again, Weber *et al.* (2010) revealed that fruit weight, pericarp thickness, acidity, ascorbic acid and lycopene were positively and significantly associated with yield per plant, while number of fruits per plant was associated negatively. According to Ara *et al.* (2009) there was a strong positive significant correlation between numbers of trusses per plant with fruit number per plant. This was because the more the truss number in a plant, such plant will produce more fruits resulting in more fruit weight. This is supported by the observed

strong positive association between fruit number per plant and fruit weight per plant. Correlation and path analysis were carried out in 67 tomato genotypes using growth, earliness, and quality and yield characters. The results indicated the inverse relationship between growth and earliness characters but strong association between growth and yield characters. Total yield per plant was positively and significantly associated with early yield per plant, equatorial diameter of the fruit, fruit volume, average fruit weight, polar diameter of the fruit, number of fruits per plant, per cent fruit set, stem girth at 90 DAT, number of locules per fruit, plant height at 60 DAT, pericarp thickness and number of seeds per fruit. Total yield per plant was negatively and significantly associated with number of flowers per cluster and number of fruits per cluster (Prashanth *et al.*, 2008). In another experiment, Kumari *et al.* (2007) observed the highest genotypic coefficient of variation for plant height followed by early yield, lycopene content, number of fruit bearing branches and titratable acidity. Wright (2007) also performed correlation analysis and observed that yield improvement can be achieved by selection for 50% flowering, plant height, number of fruits per plant along with fruit quality characters such as lycopene, beta -carotene, ascorbic acid and titratable acidity.

Anitha *et al.* (2007) found that genotypic correlations were higher than their corresponding phenotypic values and oxalate content showed significant positive correlation with seediness and a non-significant positive correlation with lycopene, TSS and locule number. Similarly, Kumari *et al.* (2007) studied correlation coefficient analysis of thirty diverse tomato genotypes and noticed that correlation coefficients at the genotypic level were generally higher than the corresponding phenotypic ones and yield per plant was positively and significantly associated with plant height, fruit number per plant, fruit shape index and pericarp thickness. Again, Megha *et al.* (2006) studied correlation in exotic tomato cultivars to determine the correlation of 26 tomato cultivars for number of flowers per cluster, flower clusters at first picking, number of fruits per cluster, weight per fruit, yield per plant, total yield, total soluble solids and juice percentage observed that improvement in yield could be managed by selection for number of flowers per cluster, flower clusters at first picking, number of fruits per cluster and weight per fruit. In another experiment, Joshi *et al.* (2004) performed correlation analysis of 37 tomato genotypes and showed that yield per plant was positively and

significantly correlated with average fruit weight, fruit length, plant height and harvest duration. The average fruit weight was positively correlated with fruit length, fruit breadth. However, fruit weight was negatively correlated with the number of fruits per plant, number of fruits per cluster and ascorbic acid content. Again, Mohanty *et al.* (2003) studied correlation coefficient analysis of 18 tomato cultivars and reported that yield was significantly and positively correlated with number of fruits per plant and number of clays to harvest, and significantly but negatively correlated with plant height, number of branches per plant and average fruit weight and the number of fruits per plant was inversely related to average fruit weight. He also reported that most early cultivars were small fruited and low yielders. Again, Nesgea *et al.* (2002) studied correlation coefficient analysis in 13 tomato genotypes and revealed that plant height, number of branches per plant, plant spread, and fresh plant weight, number of fruiting clusters, number of days to 50% flowering, number of fruits per cluster and number of fruits per plant should be considered for the enhancement of the yield of tomato.

Harer *et al.* (2002) studied correlation of thirty-seven tomato genotypes and showed that the number of fruits per cluster and number of fruits per plant were significantly and positively correlated with fruit yield per plant, whereas the number of primary branches per plant, fruit weight had negative association with fruit yield. In another experiment, Bhushana *et al.* (2001) studied correlation co-efficient in sixty genotypes of tomato and observed a positive and significant correlation between fruit yield per plant and total soluble solids, ascorbic acid, pH and titratable acidity and a positive and significant correlation was recorded among rind thickness, ascorbic acid and pH. They also observed similar association between total soluble solids and ascorbic acid, and between titratable acidity and pH. Similarly, Mahalanobis *et al.* (2001) studied correlation co-efficient in sixty genotypes of tomato and observed a positive and significant correlation between fruit yield per plant and total soluble solids, ascorbic acid, pH and titratable acidity and a positive and significant correlation was recorded among rind thickness, ascorbic acid and pH. They also observed similar association between total soluble solids and ascorbic acid and between titratable acidity and pH. Dhankar *et al.* (2001) also reported the average fruit weight under normal condition showed the highest positive effect on yield, therefore

selection for average fruit weight, number of fruits per plant and number of fruits per cluster is important for improvement of fruit yield.

2.5 Path co-efficient analysis between yield and yield contributing characters

Path co-efficient is a standard tool which measures the direct influence of one character upon another and permits the separation of correlation co-efficient into components of direct and indirect effects. It also provides valuable additional information for improving fruit yield via selection for its yield components. Recent publications involving path co-efficient analysis between yield and components of yield relevant to the present study are reviewed in this section:

The experiment also carried out by Naime (2016) consisting fifteen genotypes of tomato to study genetic diversity. This experiment revealed that path coefficient analysis showed single fruit weight had the positive correlation with fruit yield per plant. Positive direct effect was also found in plant height, number of branches per plant, number of flower per plant, days to first flowering, number of clusters per plant and number of fruits per plant. Meena and Bahadur (2015) also evaluated nineteen indeterminate tomato germplasm to estimate the nature and magnitude of associations of different characters with fruit yield and among themselves. The character showed high direct effect on yield per plant indicated that direct selection for these traits might be effective and there is a possibility of improving yield per plant through selection based on no. of flowers per plant, fruits per plant and fruit weight. Low residual effect indicates that the characters used explained almost all variability towards yield.

Path analysis revealed that average fruit weight had the high positive direct effect on yield per plant followed by number of fruits per plant. Traits viz., fruit diameter and fruit shape, fruit index had negative direct effect on fruit yield per plant. Most of the other traits had indirect effect via fruit weight, fruits per plant, fruit diameter and fruit shape index. Hence, these characters should be given more weight age in selection programme of high yielding genotypes in tomato (Khapte and Jansirani, 2014). In another experiment, Bhuiyan (2014) conducted an experiment on 18 genotypes and estimate that plant height, number of cluster per plant and number of fruit per cluster had negative

direct effect with fruit yield per plant. Number of fruit per cluster had a high negative correlation to fruit yield per plant. Fruits per plant had positive direct effect on yield and it had a positive correlation to fruit yield per plant. Similarly, Monamodi *et al.* (2013) used six determinate tomatoes. Results obtained suggest that fruit number and single fruit weight are relevant components to use as selection criteria for improving tomato yield. Path coefficient analysis results showed that marketable fruit number and single fruit weight were directly related to yield. Again, Rani *et al.* (2010) conducted a field experiment to study path coefficient for yield components and quality traits in 23 hybrids of tomato and exhibited that fruit weight had the highest positive direct effect on yield per plant, while, fruit weight was also having high positive indirect effect on yield per plant.

Path analysis revealed that early yield and average fruit weight had high direct positive effects on total yield. Hence, direct selection for early yield and average fruit weight is suggested for yield improvement (Prashanth *et al.*, 2008). In another case, Mayavel *et al.* (2005) reported that number of branches per plant had the highest positive direct effect on fruit yield. Whereas, plant height, number of fruits per cluster, number of fruits per plants and number of locules per fruit had negative direct effects on fruit yield. Similarly, Singh *et al.* (2005) performed path coefficient analysis and showed high positive direct effect of number of fruits per plant on yield followed by fruit diameter, average weight per fruit, fruit length, days to 50% flowering, number of fruits per cluster and days to first fruit harvest. However, days to first fruit set, number of primary branches per plant, plant height, number of fruit clusters per plant and total soluble solids had direct negative effects on yield.

Mohanty (2003) performed path analysis and showed that the number of branches per plant and average fruit weight exerted high positive direct effect on yield and high positive indirect effect with each other. Again, Arun *et al.* (2003) revealed that the number of fruits per plant is the most important yield contributing character followed by plant height through path co-efficient analysis. Hanson *et al.* (2002) also performed path analysis and revealed that number of branches, dry matter production, fruit weight, fruit length and fruit volume, TSS content, juice percentage and number of fruits per plant

exhibited positive effect on yield per plant at the genotypic and phenotypic levels. An experiment was carried out by Harer *et al.* (2002) to study path analysis of thirty-seven tomato genotypes and reported that number of fruits per cluster, number of fruits per plant and average fruit weight had direct maximum effects on fruit yield. Similarly, Matin *et al.* (2001) observed that the maximum direct contribution towards yield was through individual fruit weight followed by number of fruits per plant. He also reported that days to first flowering, plant height and number of seeds per fruit had negative direct effect on yield per plant. Again, Bhushana *et al.* (2001) performed path analysis for fruit quality traits on fruit yield in sixty genotypes of tomato and showed that all the four variables (total soluble solids, ascorbic acid, pH and titratable acidity) exhibited low positive direct effects on fruit yield.

A field experiment also conducted by Verma and Sarnaik (2000) to perform path analysis of yield components in thirty tomato genotypes and observed that total number of fruits per plant, average weight of fruit and number of branches per plant exhibited positive as well as high direct effects. Domini and Maya (1997) also evaluated 18 tomato varieties for the relationship of six yield components to yield in two different seasons. They reported that fruit number per plant was the most important character having a direct effect on yield either in early sowing. Genotypic and phenotypic path coefficient analysis was carried out by Aditya and Phir (1995) and revealed that plant height and number of fruits per plant had high positive direct effect on yield and on the other hand, weight of individual fruit had positive indirect effect on yield per plant. Supe and Kale (1992) studied path analysis of seven different characters of twelve indigenous varieties of tomato and observed that plant height had negative direct effect on yield per plant.

2.6 Chemical analysis

In the present world, tomatoes are the most popular vegetable crop. It has an important source of antioxidants such as lycopene, vitamin C, phenolics and total soluble solids (% of brix) in the human diet and has been linked with decreased risk of heart diseases, diabetes, prostate and various forms of cancer. Many scientists have studied quality character as well as anti-carcinogenic properties of tomato on human and many animals. Among them, most relevant recent publications are reviewed below:

2.6.1 Total Soluble Solids (% of Brix)

Brix percentage is the sugar content of an aqueous solution. One percent Brix is 1 gram of sucrose in 100 grams of solution and represents the strength of the solution as percentage by mass. If the solution contains dissolved solids other than pure sucrose, then the % Brix only approximates the dissolved solid content. Various reports are available on variation of Brix % for different genotypes of tomato. Nalla *et al.* (2014) done a field experiment using 27 tomato genotypes and reported fruit yield per plant (20.51), total soluble solids (17.38), and equatorial diameter (15.38) contributed high for divergence.

For total fruit number, total soluble solids content, fruit firmness, length and pH, in a general way and for the majority of the genotypes, there were no statistical differences between the averages of the F₁ and F₂ generations found by Hernandez (2013). A study by Silva *et al.* (2012) evaluated the components of production and total soluble solids (Brix) of tomato cultivar Carolina. The fruits were harvested when they began the color change from green to red; on the occasion were evaluated content of soluble solids, number, weight, length and diameter. Seven tomato lines studied by Chen *et al.* (2009) and found general heritability for vitamin C and total soluble solid content was high. Lines belonging to *L. esculentum* var. *cerasiforme* were better breeding materials in terms of vitamin C, organic acid and total soluble solid content.

Cheema *et al.* (2003) studies on combining ability for 10 important characters and significant general (GCA) and specific combining ability (SCA) variances were observed for different characters except for total soluble solids indicating the importance of both additive and non-additive gene effects in the expression of these characters. Four commercial brands of tomato juices and ketchups were studied. Results showed that Brix is higher in ketchup (25-33 degrees Brix) than in tomato juices (4.8-5.5 degrees Brix). Pearson correlations showed statistically significant ($P < 0.05$) correlations between Brix and HMF, lycopene, dry matter (negative correlation) and juice (negative); HMF and lycopene and dry matter (negative correlation); lycopene and dry matter (negative), pulp and juice; dry matter and pulp (negative) and juice; and pulp and juice (negative correlation). An experiment also conducted by Dhaliwal *et al.* (2002) with twelve parents and their 66 F₁ hybrids to study the genetics of traits that are important for processing and

bulk handling of tomatoes viz. TSS%, pericarp thickness, and a number of locules. The analysis of variance for combining ability exhibited the significance of both general combining ability and specific combining ability effects for all characters studied.

2.6.2 P^H

Acid concentration and pH are important quality and processing characteristics of tomatoes. Several studies have revealed that a proper sugar/acid ratio is paramount to good tomato flavor (Stevens, 1972; Simandle *et al.*, 1966 and Dennison, 1955). Both [H⁺] and potential acidity contribute to tartness (Harvey, 1920). Anderson (1957) found that pH and acidity are not always inversely related, and that in some varieties both values are relatively high. Stevens (1972) found wide variation in the [H⁺]/titratable acidity (TA) ratios among 55 divergent accessions and obtain evidence indicating that variation in phosphorus concentration of the fruits is an important factor in the poor relationship between pH and acidity. It should be possible to explain the relationship between TA and pH using model systems, as the TA is equal to the sum of TAs contributed by the buffers in the fruit. These buffers also establish the pH.

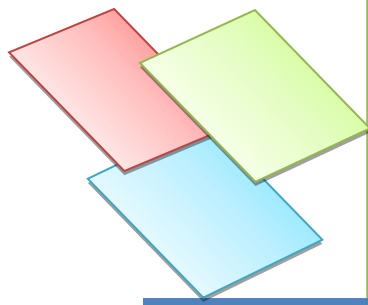

MATERIALS AND METHODS



CHAPTER III

MATERIALS AND METHODS

The experiment entitled “Genetic Variability and Character Association in F₂ Generation of Tomato (*Solanum lycopersicum* L.)” was carried out in the experimental farm of Sher-e-Bangla Agricultural University, Sher-e-Bangla Nagar, Dhaka, during Rabi season 2019 and 2020. The details of materials used for this study and methodologies followed for the experiment have been described in this chapter. This discussion emphasizes on methodologies related to the location of the experimental site, planting materials, soil and climate, preparation of seedbed, experimental design and layout, land preparation, transplantation of seedlings, fertilizing, intercultural operations, harvesting, and data recording procedure, nutritional, physiological, and statistical analyzing procedure.

3.1 Experimental site

The experiment was done in the experimental field of Sher-e-Bangla Agricultural University, Dhaka, during the period from November 2019 to March 2020. The location of the experimental site was 23°74' N latitude and 90°35' E longitude with an elevation of 8 meters from sea level (Anonymous, 2004) in the Agro-ecological zone of "Madhupur Tract" (AEZ-28) (Anonymous, 1988). The experimental site is shown in the map of AEZ-28 of Bangladesh (Appendix I).

3.2 Planting materials

There were 39 genotypes that were used for this research work. All of these 39 genotypes were the crossed materials. The germination and purity percentage were 100%. The healthy seeds of these genotypes were collected from the Department of Genetics and Plant Breeding, Sher-e-Bangla Agricultural University Dhaka. The name and origin of these genotypes are presented in Table 1.

3.3 Soil and climate

The experimental plot was situated in the subtropical zone. The soil was clay loam in texture and olive-grey with common fine to medium distinct dark yellowish brown mottle

Table 1. Name and origin of 39 tomato genotypes used in the present study

Sl. No	Genotypes	Name/Accession No.	Source of collection
1	G ₁ ×G ₃	SL-006 × SL-008	GEPB, SAU
2	G ₁ ×G ₄	SL-006 × SL-009	
3	G ₁ ×G ₅	SL-006 × SL-010	
4	G ₁ ×G ₆	SL-006 × SL-011	
5	G ₁ ×G ₇	SL-006 × SL-012	
6	G ₂ ×G ₁	SL-007 × SL-006	
7	G ₂ ×G ₃	SL-007 × SL-008	
8	G ₂ ×G ₄	SL-007 × SL-009	
9	G ₂ ×G ₅	SL-007 × SL-010	
10	G ₂ ×G ₇	SL-007 × SL-012	
11	G ₂ ×G ₈	SL-007 × SL-013	
12	G ₃ ×G ₁	SL-008 × SL-006	
13	G ₃ ×G ₂	SL-008 × SL-007	
14	G ₃ ×G ₄	SL-008 × SL-009	
15	G ₃ ×G ₅	SL-008 × SL-010	
16	G ₃ ×G ₈	SL-008 × SL-013	
17	G ₄ ×G ₁	SL-009 × SL-006	
18	G ₄ ×G ₂	SL-009 × SL-007	
19	G ₄ ×G ₃	SL-009 × SL-008	
20	G ₄ ×G ₅	SL-009 × SL-010	
21	G ₄ ×G ₆	SL-009 × SL-011	
22	G ₄ ×G ₇	SL-009 × SL-012	
23	G ₄ ×G ₈	SL-009 × SL-013	
24	G ₅ ×G ₂	SL-010 × SL-007	
25	G ₅ ×G ₃	SL-010 × SL-008	
26	G ₅ ×G ₆	SL-010 × SL-011	
27	G ₅ ×G ₈	SL-010 × SL-013	
28	G ₆ ×G ₂	SL-011 × SL-007	
29	G ₆ ×G ₃	SL-011 × SL-008	
30	G ₆ ×G ₅	SL-011 × SL-010	
31	G ₆ ×G ₇	SL-011 × SL-012	
32	G ₇ ×G ₁	SL-012 × SL-006	
33	G ₇ ×G ₂	SL-012 × SL-007	
34	G ₇ ×G ₃	SL-012 × SL-008	
35	G ₇ ×G ₅	SL-012 × SL-010	
36	G ₇ ×G ₆	SL-012 × SL-011	
37	G ₇ ×G ₈	SL-012 × SL-013	
38	G ₈ ×G ₁	SL-013 × SL-006	
39	G ₈ ×G ₅	SL-013 × SL-010	

GEPB= Department of Genetics and Plant Breeding, SAU= Sher-e-Bangla Agricultural University

that belongs to the Agro-ecological region of “Madhupur Tract” (AEZ No. 28) with pH 5.47 to 5.63 and 0.82% organic carbon content (Appendix II). The experimental was held in the month of November to March. The monthly average minimum and maximum temperature and relative humidity during the crop period was 16.75°C to 22.45°C and 57% to 76%, respectively. The monthly average rainfall was 37 mm. Details of the metrological data of air, temperature, relative humidity, rainfall and sunshine hour during the period of the experiment were noted from Bangladesh Metrological Department, Sher-e-Bangla Nagar, Dhaka-1207 and presented in Appendix III.

3.4 Seedbed preparation and seedling raising

Sowing of the tomato seeds was done on 24th October 2019. Before sowing all the seeds were treated with Bavistin (Carbendazim 50% WP) for 5 minutes. All the seedlings of the genotypes were raised in the seedbed of Sher-e-Bangla Agricultural University, Dhaka. Seeds were sown in rows spaced at 10 cm apart. The beds were watered regularly. All the recommended cultural practices were taken to raising the seedling properly. After 29 days, the seedlings were transplanted in the main field. Seedbed and seedling raising are shown in Plate 1(A-D).

3.5 Design and layout

The experiment was carried out under field condition during Rabi season 2019-2020 in the Randomized Complete Block Design (RCBD) method. There were 39 genotypes and 3 replications in the experiment. The genotypes were distributed randomly to every row within every line. The distance row to row and plant to plant distance was 50 cm and 40 cm. The size of the plot was 18 m (length) and 12 m (width). Layout of the experimental design is presented in Appendix IV.

3.6 Land preparation

The land was ploughed and cross ploughed followed by laddering to ensure good tillage seven days before transplanting. Weeds and other unwanted plants were removed thoroughly. Cow dung and fertilizer of required doses were applied in the field for good tith. Slight watering was done frequently to keep the soil moist. Pits were prepared for



Plate 1. Different seedling stage on seedbed A. Seedlings on the seedbed at early stage B. Seedlings at 15 days C. Seedlings at mature stage D. Supervisor exhibition before transplanting

transplanting the seedlings. The final land preparation was done on 21 November, 2019. Land preparation is shown in Plate 2A.

3.7 Manure and fertilizers application

One third of urea, total TSP (Triple Super Phosphate), half of the MoP (Muriate of Potash), total Boric acid, total Zinc, total Gypsum and cow dung were used before one day of transplanting. The remaining Urea and MoP (Muriate of Potash) were used as top dressing at the time of 15 DAT (Days after Transplanting) and during 1st flowering. Fertilizer and manure doses are given in Table 2.

Table 2. Doses of manures and fertilizers used in the experiment

SL. No	Fertilizers/Manures	Applied in the plot	Quantity
1	Urea	8 kg	450 kg/ha
2	TSP (Triple Super Phosphate)	6 kg	350 kg/ha
3	MoP (Muriate of Potash)	4 kg	250 kg/ha
4	Boric acid	500 g	30 kg/ha
5	Zinc	500 g	30 kg/ha
6	Gypsum	5 kg	280 kg/ha
7	Cow dung	200 kg	10 ton/ha

3.8 Transplanting of seedlings

The seedlings were transplanted in the main field on 22th November 2019 when they were 29 days old. The seedlings were watered regularly so that the root could make a firm relation with soil to stand along.

3.9 Intercultural operations

After establishing seedlings, 1st mulching and weeding were done. Then second weeding was done during the 2nd installment of urea 15 DAT (days after transplanting). When the seedlings became large, bamboo sticks and ropes were used for supporting the plants. Some lateral branches and leaf were pruned out for obtaining proper sunlight and to reduce the infestation of insects. Different intercultural operations are shown in Plate 2 (B-D).



Plate 2. Land preparation and different intercultural operations A. Final land preparation
B. Pesticide application C. Staking of the plant D. Watering of the plant

I. Thinning and gap filling

After some days of transplanting when the seedlings became established, some new plants were planted at the place of dead seedlings to fill up the gap. Thinning was done to avoid the density of seedlings.

II. Weeding and mulching

Weeding and mulching were done several times after transplanting in the main field. Mulching was done for proper aeration and weeding was done to reduce the competition with the tomato plant.

III. Staking

Staking was done to keep the plants erect and for proper aeration. Staking was done by using bamboo stick and rope.

IV. Pesticide application

At the time of the cropping period, “Ripcord” (Cypermethrin10 EC) was used about 7 times at 7 day’s interval during sunny days to prevent insect infestation. No herbicide was used to control the weeds. Only hand weeding was done.

V. Irrigation and drainage

The seedlings were properly irrigated for consecutive 7 days after transplanting. The irrigation was done at the time of urea application also. The flood irrigation was done during the fruiting stage. Drainage was done at the time of requirements.

3.10 Harvesting and Processing

Fruits were harvested in the maturity stage when fruits started ripening. Harvesting continued for about one and a half month as all the genotypes used in this experiment were indeterminate type and matured progressively at different dates and over a long period. After collection some fruits were used for chemical analysis and from some fruits seeds were collected and stored in 4°C for 3rd season and future use. Harvesting was started on 19 February, 2020 and completed by 31 March, 2020. Harvested fruits are shown in Plate 3(A-B).

3.11. Data recording

Data were recorded from each plot based on different yield and yield contributing, physiological and nutritional traits. A view of data collection and supervisor field exhibition in the experimental site is shown in Plate 3(C-D).

3.11.1 Agro-morphological traits

Data for some physical parameters related to yield and yield contributing characters were recorded during the experiment. These traits are as following:

3.11.1.1 Days to first flowering

Number of days required for first flower formation was recorded as the days passed from seedling transplanting to first flowering. The mean value of five plants was considered as the days to first flowering for each plot.

3.11.1.2 Days to 50% flowering

Number of days when flower at 50% plant of each genotype was formed was counted as the days passed from seedling transplanting to flowering in half of the plants. The mean value of five plants was considered as the days to 50% flowering for each plot.

3.11.1.3 Days to first fruiting

Number of days required for first fruit formation was recorded as the days passed from seedling transplanting to first fruiting. The mean value of five plants was considered as the days to first fruiting for each plot.

3.11.1.4 Days to Maturity

The number of days needed for the plant to mature for fruit ripening was counted from the date of transplanting to date of first harvesting.

3.11.1.5 Plant height (cm)

The plant height was measured from ground level to tip of the plant expressed in centimeters (cm) and mean was computed. The mean value of five plants was considered as the plant height for each plot.



Plate 3. Data collection and harvesting of fruits A. Different genotypic fruits were harvested separately B. Fruits was stored in a basket C. Data collection for Agro-morphological traits D. Supervisor field exhibition during data collection

3.11.1.6 Number of branches per plant

Number of branches per plant was counted from each of the selected plant during the maturity stage. The mean value of five plants was considered as the number of branches per plant for each plot.

3.11.1.7 Number of clusters per plant

At the time of harvesting number of clusters per plant was recorded. The mean value of five plants was considered as the number of cluster per plant for each plot.

3.11.1.8 Number of flowers per cluster

The number of flower per plant was recorded at the time of flowering. The mean value of five plants was considered as the number of flower per clusters for each plot.

3.11.1.9 Number of fruits per cluster

All fruits in one cluster were recorded by randomly selecting five clusters in every selected plant. The mean value of five plants was considered as the number of fruits per cluster for each plot.

3.11.1.10 Number of fruits per plant

Number of fruits per plant was recorded during the maturity stage of plants from five plants from each genotype from each plot at random. The mean value of five plants was considered as the number of fruits per plants for each plot.

3.11.1.11 Fruit length (cm)

Fruit length was measured with a digital slide caliper from the neck of the fruit to the bottom of the same from five representative fruits of each genotype and their average was taken as the length of the fruit.

3.11.1.12 Fruit diameter (cm)

Fruit breadth was measured along the equatorial part of the same five representative fruits taken for fruit length by digital slide caliper and their average was taken as the breadth of the fruit.

3.11.1.13 Skin diameter (mm)

Five fruits of each replication of every genotype were cut into equal part horizontally and their skin diameter was measured by using slide caliper. The mean value of five representative fruits skin diameter of each genotype was calculated and considered as skin diameter of the fruit.

3.11.1.14 Locule number

Five fruits of each replication of every genotype were cut into equal part horizontally and the number of locules per fruit was recorded.

3.11.1.15 Individual fruit weight (g)

Individual fruit weight was measured by picking fruit from each genotype and measured its weight by electric precision balance and their mean value was calculated.

3.11.1.16 Yield per plant (kg)

As all the genotypes were indeterminate type, fruits ripened at different times in the same plant of the same genotype. So, when harvested every time number of fruits harvested from each plant and their weight was recorded and finally after final harvest their average weight was calculated as yield per plant.

3.11.2 Nutritional traits

Nutritional quality describes the inherent biological or health value of produce including the ratio of beneficial to harmful substance, taste, fragrance, freshness, and shelf-life. Some nutritional parameters of tomato named Brix (%), P^H of fruit was measured from ripe fruits.

3.11.2.1 Determination of fruit juice P^H

Fruit juice was collected from a single fruit of each genotype by blending it to measure fruit p^H using REX p^H meter model-PHS-3C. The electrode was inserted into the juice to get p^H value. p^H determination was shown Plate 4 (A-C).

3.11.2.2 Brix percentage (%)

With the help of portable Refractometer (ERMA, Tokyo, Japan), Brix percentages was measured at room temperature. Fruit juice was collected from a single fruit of each genotype by blending it to measure Brix percentage (%). Determination of Brix % was shown in Plate 4(A-D).

3.11.3 Physiological traits

Physiological traits *viz.* relative water content (RWC) and moisture percentage (MP) in fruit was noted. Relative water content is an important parameter in water relation studies, e.g. it allows the calculation of the osmotic potential at full turgor. Moisture content can be described by the percentage equivalent of the ratio of the weight of water to the weight of the plant material. It can be range from 0 to 100 percent.

3.11.3.1 Relative water content (RWC)

Barrs and Weatherly (1962) method was followed to measure relative water content (RWC). Whole fresh plant was weighted. Then the plant was kept in emerged water under light until the weight stayed constant to attain full turgid and then turgid weight was recorded. Then the plant was kept in hot air oven at 60°C for 72 hours and the dry weight was recorded. Finally, the following formula was used to calculate relative water content (RWC),

$$\text{Relative water content (\%)} = \frac{(\text{Fresh weight} - \text{Dry weight})}{(\text{Turgid weight} - \text{Dry weight})} \times 100$$

3.11.3.2 Moisture percentage

Three samples were used for each variety. Percent of moisture was calculated according to the following formula:

$$\text{Moisture Percentage (\%)} = \frac{(\text{Weight of fresh fruit} - \text{Weight of oven dry fruit})}{\text{Weight of fresh fruit}} \times 100$$



Plate 4. Data collection for nutritional traits A. Fresh Tomatoes B. Tomato juice for chemical analysis C. Determination of fruit p^H D. Determination of brix%

3.12 Statistical analysis

Mean data of the characters were subjected to multivariate analysis. Univariate analysis of the individual character was done for all characters under study using the mean values (Singh and Chaudhury, 1985) and was estimated using MSTAT-C computer programme. Duncan's Multiple Range Test (DMRT) was performed for all the characters to test the differences between the means of the genotypes. Mean, range and coefficient of variation (CV %) were also estimated using MSTAT-C.

3.12.1 Estimation of genotypic and phenotypic variances

Genotypic and phenotypic variances were estimated according to the formula given by Johnson *et al.* (1955).

$$\text{Genotypic variance, } \sigma_g^2 = \frac{\text{GMS} - \text{EMS}}{r}$$

Where,

GMS = Genotypic mean sum of squares

EMS = Error mean sum of square

r = number of replications

$$\text{Phenotypic variance, } \sigma_{p^H}^2 = \sigma_g^2 + \text{EMS}$$

Where,

σ_g^2 = Genotypic variance

EMS = Error mean sum of square

$$\text{Environmental variance } (\sigma^2_e) = \text{EMS}$$

Where,

EMS = Mean Square Error

3.12.2 Estimation of genotypic and phenotypic coefficient of variation

Genotypic and phenotypic coefficient of variation was calculated by the formula suggested by Burton (1952)

$$\text{Genotypic co-efficient of variation, GCV \%} = \frac{\sqrt{\sigma^2_g}}{\bar{x}} \times 100$$

Where,

σ^2_g = Genotypic variance

\bar{x} = Population mean

Similarly,

The phenotypic co-efficient of variation was calculated from the following formula.

$$\text{Phenotypic co-efficient variation, PCV} = \frac{\sqrt{\sigma^2_{ph}}}{\bar{x}} \times 100$$

Where,

σ^2_{ph} = Phenotypic variance

\bar{x} = Population mean

3.12.3 Estimation of heritability

Broad-sense heritability was estimated (Lush, 1943) by the following formula, suggested by Johnson *et al.* (1955).

$$\text{Heritability, } h^2_b \% = \frac{\sigma^2_g}{\sigma^2_{ph}} \times 100$$

Where,

h^2_b = Heritability in broad sense

σ^2_g = Genotypic variance

σ^2_{ph} = Phenotypic variance

3.12.4 Estimation of genetic advance

The expected genetic advance for different characters under selection was estimated using the formula suggested by Lush (1943) and Johnson *et al.* (1955).

$$\text{Genetic advance, GA} = K \cdot h^2 \cdot \sigma_p$$

Or Genetic advance, $GA = K \cdot \frac{\sigma_g^2}{\sigma_{ph}^2} \cdot \sigma_{ph}$

Where,

K = Selection intensity, the value which is 2.06 at 5% selection intensity

σ_{ph} = Phenotypic standard deviation

h^2_b = Heritability in broad sense

σ_g^2 = Genotypic variance

σ_{ph}^2 = Phenotypic variance

3.12.5 Estimation of genetic advance mean's percentage

Genetic advance as a percentage of the mean was calculated from the following formula as proposed by Comstock and Robinson (1952):

$$\text{Genetic advance (\% of mean)} = \frac{\text{Genetic Advance}}{\text{Population mean } (\bar{x})} \times 100$$

3.12.6 Estimation of simple correlation coefficient

Simple correlation coefficient (r) was estimated with the following formula (Clarke, 1973; Singh and Chaudhary, 1985).

$$r = \frac{\sum xy - \frac{\sum x \cdot \sum y}{N}}{\sqrt{[\sum x^2 - \frac{(\sum x)^2}{N}] [\sum y^2 - \frac{(\sum y)^2}{N}]}}$$

Where,

\sum = Summation

x and y are the two variables correlated

N = Number of observation

3.12.7 Estimation of genotypic and phenotypic correlation coefficient

For calculating the genotypic and phenotypic correlation coefficient for all possible combinations the formula suggested by Miller *et al.* (1990), Johnson *et al.* (1955) and Hanson *et al.* (2002) were adopted. The genotypic co-variance component between two traits and have the phenotypic co-variance component were derived in the same way as for the corresponding variance components. The covariance components were used to compute the genotypic and phenotypic correlation between the pairs of characters as follows:

$$\text{Genotypic correlation, } r_{gxy} = \frac{GCOV_{xy}}{\sqrt{GV_x.GV_y}} = \frac{\sigma_{gxy}}{\sqrt{(\sigma_{gx}^2.\sigma_{gy}^2)}}$$

Where,

σ_{gxy} = Genotypic co-variance between the traits x and y

σ_{gx}^2 = Genotypic variance of the trait x

σ_{gy}^2 = Genotypic variance of the trait y

$$\text{Phenotypic correlation } (r_{pxy}) = \frac{PCOV_{xy}}{\sqrt{PV_x.PV_y}} = \frac{\sigma_{pxy}}{\sqrt{(\sigma_{px}^2.\sigma_{py}^2)}}$$

Where,

σ_{pxy} = Phenotypic covariance between the trait x and y

σ_{px}^2 = Phenotypic variance of the trait x

σ_{py}^2 = Phenotypic variance of the trait y

3.12.8 Estimation of path co-efficient

It was done according to the procedure employed by Dewey and Lu (1959) also quoted in Singh and Chaudhary (1985), using phenotypic correlation coefficient values. In path analysis, correlation coefficients between yield and yield contributing characters were partitioned into direct and indirect effects on yield per hectare. In order to estimate direct

and indirect effects of the correlated characters, i. e. 1, 2, 3....and 12 on yield y, a set of simultaneous equations (twelve equations in this example) is required to be formulated as shown below:

$$r_{1,y} = P_{1,y} + r_{1.2} P_{2,y} + r_{1.3} P_{3,y} + r_{1.4} P_{4,y} + r_{1.5} P_{5,y} + r_{1.6} P_{6,y} + r_{1.7} P_{7,y} + r_{1.8} P_{8,y} + r_{1.9} P_{9,y} + r_{1.10} P_{10,y} + r_{1.11} P_{11,y} + r_{1.12} P_{12,y}$$

$$r_{2,y} = r_{1.2} P_{1,y} + P_{2,y} + r_{2.3} P_{3,y} + r_{2.4} P_{4,y} + r_{2.5} P_{5,y} + r_{2.6} P_{6,y} + r_{2.7} P_{7,y} + r_{2.8} P_{8,y} + r_{2.9} P_{9,y} + r_{2.10} P_{10,y} + r_{2.11} P_{11,y} + r_{2.12} P_{12,y}$$

$$r_{3,y} = r_{1.3} P_{1,y} + r_{2.3} P_{2,y} + P_{3,y} + r_{3.4} P_{4,y} + r_{3.5} P_{5,y} + r_{3.6} P_{6,y} + r_{3.7} P_{7,y} + r_{3.8} P_{8,y} + r_{3.9} P_{9,y} + r_{3.10} P_{10,y} + r_{3.11} P_{11,y} + r_{3.12} P_{12,y}$$

$$r_{4,y} = r_{1.4} P_{1,y} + r_{2.4} P_{2,y} + r_{3.4} P_{3,y} + P_{4,y} + r_{4.5} P_{5,y} + r_{4.6} P_{6,y} + r_{4.7} P_{7,y} + r_{4.8} P_{8,y} + r_{4.9} P_{9,y} + r_{4.10} P_{10,y} + r_{4.11} P_{11,y} + r_{4.12} P_{12,y}$$

$$r_{5,y} = r_{1.5} P_{1,y} + r_{2.5} P_{2,y} + r_{3.5} P_{3,y} + r_{4.5} P_{4,y} + P_{5,y} + r_{5.6} P_{6,y} + r_{5.7} P_{7,y} + r_{5.8} P_{8,y} + r_{5.9} P_{9,y} + r_{5.10} P_{10,y} + r_{5.11} P_{11,y} + r_{5.12} P_{12,y}$$

$$r_{6,y} = r_{1.6} P_{1,y} + r_{2.6} P_{2,y} + r_{3.6} P_{3,y} + r_{4.6} P_{4,y} + r_{5.6} P_{5,y} + P_{6,y} + r_{6.7} P_{7,y} + r_{6.8} P_{8,y} + r_{6.9} P_{9,y} + r_{6.10} P_{10,y} + r_{6.11} P_{11,y} + r_{6.12} P_{12,y}$$

$$r_{7,y} = r_{1.7} P_{1,y} + r_{2.7} P_{2,y} + r_{3.7} P_{3,y} + r_{4.7} P_{4,y} + r_{5.7} P_{5,y} + r_{6.7} P_{6,y} + P_{7,y} + r_{7.8} P_{8,y} + r_{7.9} P_{9,y} + r_{7.10} P_{10,y} + r_{7.11} P_{11,y} + r_{7.12} P_{12,y}$$

$$r_{8,y} = r_{1.8} P_{1,y} + r_{2.8} P_{2,y} + r_{3.8} P_{3,y} + r_{4.8} P_{4,y} + r_{5.8} P_{5,y} + r_{6.8} P_{6,y} + r_{7.8} P_{7,y} + P_{8,y} + r_{8.9} P_{9,y} + r_{8.10} P_{10,y} + r_{8.11} P_{11,y} + r_{8.12} P_{12,y} +$$

$$r_{9,y} = r_{1.9} P_{1,y} + r_{2.9} P_{2,y} + r_{3.9} P_{3,y} + r_{4.9} P_{4,y} + r_{5.9} P_{5,y} + r_{6.9} P_{6,y} + r_{7.9} P_{7,y} + r_{8.9} P_{8,y} + P_{9,y} + r_{9.10} P_{10,y} + r_{9.11} P_{11,y} + r_{9.12} P_{12,y} +$$

$$r_{10,y} = r_{1.10} P_{1,y} + r_{2.10} P_{2,y} + r_{3.10} P_{3,y} + r_{4.10} P_{4,y} + r_{5.10} P_{5,y} + r_{6.10} P_{6,y} + r_{7.10} P_{7,y} + r_{8.10} P_{8,y} + r_{9.10} P_{9,y} + P_{10,y} + r_{10.11} P_{11,y} + r_{10.12} P_{12,y}$$

$$r_{11,y} = r_{1.11} P_{1,y} + r_{2.11} P_{2,y} + r_{3.11} P_{3,y} + r_{4.11} P_{4,y} + r_{5.11} P_{5,y} + r_{6.11} P_{6,y} + r_{7.11} P_{7,y} + r_{8.11} P_{8,y} + r_{9.11} P_{9,y} + r_{10.11} P_{10,y} + P_{11,y} + r_{11.12} P_{12,y} + r_{11.13} P_{13,y}$$

$$r_{12,y} = r_{1.12} P_{1,y} + r_{2.12} P_{2,y} + r_{3.12} P_{3,y} + r_{4.12} P_{4,y} + r_{5.12} P_{5,y} + r_{6.12} P_{6,y} + r_{7.12} P_{7,y} + r_{8.12} P_{8,y} + r_{9.12} P_{9,y} + r_{10.12} P_{10,y} + r_{11.12} P_{11,y} + P_{12,y}$$

$$r_{13,y} = r_{1.12} P_{1,y} + r_{2.12} P_{2,y} + r_{3.12} P_{3,y} + r_{4.12} P_{4,y} + r_{5.12} P_{5,y} + r_{6.12} P_{6,y} + r_{7.12} P_{7,y} + r_{8.12} P_{8,y} + r_{9.12} P_{9,y} + r_{10.12} P_{10,y} + r_{11.12} P_{11,y} + P_{12,y}$$

$$r_{14,y} = r_{1.12} P_{1,y} + r_{2.12} P_{2,y} + r_{3.12} P_{3,y} + r_{4.12} P_{4,y} + r_{5.12} P_{5,y} + r_{6.12} P_{6,y} + r_{7.12} P_{7,y} + r_{8.12} P_{8,y} + r_{9.12} P_{9,y} + r_{10.12} P_{10,y} + r_{11.12} P_{11,y} + P_{12,y}$$

$$r_{15,y} = r_{1.12} P_{1,y} + r_{2.12} P_{2,y} + r_{3.12} P_{3,y} + r_{4.12} P_{4,y} + r_{5.12} P_{5,y} + r_{6.12} P_{6,y} + r_{7.12} P_{7,y} + r_{8.12} P_{8,y} + r_{9.12} P_{9,y} + r_{10.12} P_{10,y} + r_{11.12} P_{11,y} + P_{12,y}$$

Where,

r_{1y} = Genotypic correlation coefficients between y and I th character (y = Fruit yield)

P_{iy} = Path coefficient due to i th character (i= 1, 2, 3,...12)

1 = Days to first flowering

2 = Plant height

3 = Days to maturity

4 = Number of clusters per plant

5 = Number of flowers per plant

6 = Number of fruits per cluster

7 = Number of fruits per plant

8 = Fruit weight (g)

9= Fruit length (cm)

10 = Fruit diameter (cm)

11 = Fruit yield per plant (kg)

Total correlation, say between 1 and y i. e., r_{1y} is thus partitioned as follows:

$P_{1,y}$ = the direct effect of 1 on y

$r_{1.2} P_{2,y}$ = indirect effect of 1 via 2 on y

$r_{1.3} P_{3,y}$ = indirect effect of 1 via 3 on y

$r_{1.4} P_{4,y}$ = indirect effect of 1 via 4 on y

$r_{1.5} P_{5,y}$ = indirect effect of 1 via 5 on y

$r_{1.6} P_{6,y}$ = indirect effect of 1 via 6 on y

$r_{1.7} P_{7,y}$ = indirect effect of 1 via 7 on y

$r_{1.8} P_{8,y}$ = indirect effect of 1 via 8 on y

$r_{1.9} P_{9,y}$ = indirect effect of 1 via 9 on y

$r_{1.10} P_{10,y}$ = indirect effect of 1 via 10 on y

$r_{1.11} P_{11,y}$ = indirect effect of 1 via 11 on y

$r_{1.12} P_{12,y}$ = indirect effect of 1 via 12 on y

$r_{1.13} P_{12,y}$ = indirect effect of 1 via 13 on y

$r_{1.14} P_{12,y}$ = indirect effect of 1 via 14 on y

$r_{1.15} P_{12,y}$ = indirect effect of 1 via 15 on y

Where,

$P_{1,y}, P_{2,y}, P_{3,y}, \dots, P_{15,y}$ = Path coefficient of the independent variables 1, 2, 3, ..., 15 on the dependent variable y, respectively.

$r_{1,y}, r_{2,y}, r_{3,y}, \dots, r_{15,y}$ = Correlation coefficient of 1, 2, 3, ..., 15 with y, respectively.

After calculating the direct and indirect effect of the characters, residual effect (R) was calculated by using the formula (Singh and Chaudhary, 1985) given below

$$P^2_{RY} = 1 - (r_{1,y}P_{1,y} + r_{2,y}P_{2,y} + \dots + r_{15,y}P_{15,y})$$

Where,

$$P^2_{RY} = R^2$$

and hence residual effect, $R = (P^2_{RY})^{1/2}$

$P_{1,y}$ = Direct effect of the i th character on yield y.

$r_{1,y}$ = Correlation of the i th character with yield y.

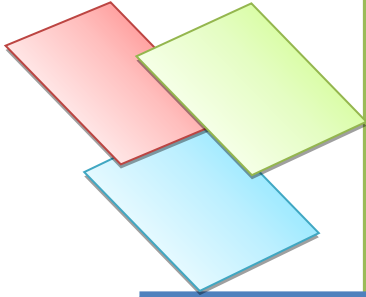

RESULTS AND DISCUSSION



CHAPTER IV

RESULT AND DISCUSSION

The experiment was conducted to execute the character association and path coefficient analysis of 39 Tomato (*Solanum Lycopersicum* L.) genotypes using yield contributing and nutritional traits. Twenty characters such as days to first flowering, days to 50% flowering, days to first fruiting, days to maturity, plant height (cm), number of branches per plant, number of clusters per plant, number of flowers per cluster, number of fruits per cluster, number of fruits per plant, fruit length (cm), fruit diameter (cm), skin diameter (mm), number of locules per fruit, total soluble solids, p^H, relative water content, moisture percentage, individual fruit weight (kg) and yield per plant (kg), were studied. This chapter comprises the presentation and discussion of the findings obtained from the experiment. The data pertaining to twenty characters have been presented and statistically analyzed with the possible interpretations.

4.1 Genetic parameters

The analysis of variance indicated significantly higher amount of variability present among the genotypes for the characters studied viz., days to first flowering, days to 50% flowering, days to first fruiting, days to maturity, plant height (cm), number of branches per plant, number of clusters per plant, number of flowers per cluster, number of fruits per cluster, number of fruits per plant, fruit length (cm), fruit diameter (cm), skin diameter (mm), locule number, total soluble solids, p^H, relative water content, moisture percentage, individual fruit weight (kg) and yield per plant (kg) (Appendix V). The mean performance of all the 20 characters is presented in Appendix VI.

4.2 Genetic variability, heritability and genetic advance

The mean values for each character of all the genotypes are shown in (Appendix VI). Performance of the genotypes is described below for each character. The extent of variation among the genotypes in respect of twenty characters were studied and the mean, phenotypic variance (σ^2_p), genotypic variance (σ^2_g), phenotypic coefficient of variation (PCV), genotypic coefficient of variation (GCV), heritability (h^2_b), genetic advance (GA), and genetic advance in percent of mean are shown in (Table 3). The data were

analyzed and possible interpretations are given here based on established scales. According to Deshmukh *et al.* (1986) PCV and GCV can be categorized as low (<10%), moderate (10-20%) and high (>20%). Wide difference between PCV and GCV for the traits implies their susceptibility to environmental fluctuation, whereas narrow difference suggested their relative resistant to environmental alteration. Heritability is the percentage of phenotypic variance that is attributed to genetic variance. According to Singh (2009), heritability of a trait is considered as very high or high when the values is 80% or more and moderate when it ranged from 40-80% and when it is less than 40%, it is low. Therefore, the heritability estimates appears to be more meaningful when accompanied by estimates of genetic advance and the genetic advance at percentage of mean. Deshmukh *et al.* (1986) classified genetic advance as percentage of mean as low (<10%), moderate (10-20%) and high (>20%).

4.2.1 Days to first flowering

The variance due to days to first flowering showed that the genotypes differed significantly (Appendix V) and ranged from 24.33 days after transplanting (DAT) in ($G_7 \times G_5$) to 44.33 DAT in ($G_3 \times G_1$) with mean value 37.701 days after transplanting (DAT) (Appendix VI). The genotypic variance and the phenotypic variance for this trait were 9.07 and 35.91, respectively (Table 3). The genotypic variance appeared to be higher than the phenotypic variance suggested considerable influence of environment on the expression of genes controlling this trait. The GCV (7.99) and PCV (15.90) were low and moderate (Table 3). Wide difference between PCV and GCV for the character implies their susceptibility to environmental fluctuation that was not desirable for the improvement of this crop. Samadia *et al.*, 2006; Singh *et al.*, 2005; Manivannan *et al.*, 2005; Singh *et al.*, 2002 and Korla *et al.*, 1998 showed that the PCV was higher than GCV for several characters in his study of tomato. The heritability estimates for days to first flowering was low (25.25%) with low genetic advance (3.12%) and genetic advance in percentage of mean (8.27%) (Table 3) indicating that this trait was mostly controlled by non-additive genes and selection would be ineffective. This suggested that the low heritability of traits due to the influence of environment and limit the scope of improvement using selection.

Table 3. Estimation of genetic parameters of 39 genotypes in tomato

Parameters	Mean	σ^2_p	σ^2_g	σ^2_e	PCV	GCV	ECV	Heritability	Genetic Advance (5%)	Genetic Advance (% of mean)
Days to first flowering	37.70	35.91	9.07	26.84	15.90	7.99	7.91	25.25	3.12	8.27
Days to 50% flowering	76.92	13.14	11.02	2.11	4.71	4.32	0.40	83.91	6.27	8.14
Days to first fruiting	61.07	64.17	20.63	43.54	13.12	7.44	5.68	32.15	5.31	8.69
Days to maturity	99.61	48.25	40.93	7.32	6.97	6.42	0.55	84.83	12.14	12.19
Plant height (cm)	87.80	86.70	22.58	64.12	10.61	5.41	5.19	26.05	5.00	5.69
No. of branches per plant	9.75	2.20	0.50	1.70	15.22	7.26	7.96	22.77	0.70	7.14
No. of clusters per plant	19.97	15.72	4.98	10.74	19.86	11.18	8.68	31.70	2.59	12.97
No. of flowers per cluster	7.44	1.41	0.23	1.18	15.95	6.42	9.53	16.22	0.40	5.33
No. of fruits per cluster	5.99	0.77	0.36	0.41	14.66	10.07	4.59	47.20	0.85	14.25
No. of fruits per plant	119.83	862.21	325.50	536.71	24.50	15.06	9.45	37.75	22.84	19.06
Fruit length (cm)	19.22	56.15	43.91	12.24	38.98	34.48	4.51	78.21	12.07	62.81
Fruit diameter (cm)	21.03	54.02	43.10	10.92	34.95	31.21	3.73	79.78	12.08	57.43
Skin diameter (mm)	4.40	0.63	0.44	0.19	18.04	15.08	2.96	69.91	1.14	25.98
Locule number	3.03	1.80	1.48	0.32	44.19	40.05	4.15	82.11	2.27	74.75
Total soluble solids	2.60	1.91	1.91	0.00	53.12	53.09	0.04	99.87	2.84	109.28
pH	4.49	0.24	0.23	0.00	10.81	10.77	0.04	99.24	0.99	22.10
Relative water content	75.94	105.98	100.07	5.91	13.56	13.17	0.38	94.43	20.02	26.37
Moisture percentage	97.94	3.38	3.13	0.25	1.88	1.81	0.07	92.52	3.51	3.58
Individual fruit weight (g)	27.99	126.27	125.75	0.52	40.14	40.06	0.08	99.59	23.05	82.36
Yield per plant (kg)	3.19	0.96	0.66	0.30	30.73	25.43	5.30	78.49	1.38	43.36

σ^2_p : Phenotypic variance
 σ^2_g : Genotypic variance
 σ^2_e : Environmental variance

PCV: Phenotypic coefficient of variation
GCV: Genotypic coefficient of variation
ECV: Environmental coefficient of variation

GAM: Genetic advance (% of mean)
GA (5%): Genetic advance

A genetic advance in percent of mean was low which is in accordance with the findings of Kumar *et al.* (2006) and Singh *et al.* (1993).

4.2.2. Days to 50% flowering

The variance due to days to 50% flowering showed that the genotypes differed significantly (Appendix V) and ranged from 72.00 days after transplanting (DAT) in ($G_2 \times G_7$, $G_3 \times G_2$, $G_6 \times G_7$, $G_7 \times G_3$, $G_7 \times G_6$) to 82.00 DAT in ($G_6 \times G_3$) with mean value 76.92 days after transplanting (DAT) (Appendix VI). The genotypic variance and the phenotypic variance for this trait were 11.02 and 13.14, respectively (Table 3). The phenotypic variance appeared to be higher than the genotypic variance suggested considerable influence of environment on the expression of genes controlling this trait. The GCV (4.32) and PCV (4.71) were more or less similar to each other (both were low), indicating the presence of low variability in this trait (Table 3) which is same as the findings of Bhuiyan *et al.* (2016) and Singh *et al.* (2002). The heritability estimates for days to 50% flowering was high (83.91%) with low genetic advance (6.27%) and genetic advance in percentage of mean (8.14%) (Table 3). High heritability coupled with low genetic advance was obtained for days to 50% flowering, indicating that this trait was mostly controlled by non-additive gene and selection would be ineffective. Islam and Khan (1991) reported high heritability in his study of tomato. High heritability coupled with low genetic advance was observed for days to 50% flowering by Kumar *et al.* (2004) and Singh *et al.* (1993).

4.2.3 Days to first fruiting

The variance due to days to first fruiting showed that the genotypes differed significantly (Appendix V) and ranged from 49.33 days after transplanting (DAT) in ($G_6 \times G_7$, $G_7 \times G_6$) to 72.00 DAT in ($G_7 \times G_1$) with mean value 61.07 days after transplanting (DAT) (Appendix VI). The genotypic variance and the phenotypic variance for this trait were 20.63 and 64.17, respectively (Table 3). The phenotypic variance appeared to be higher than the genotypic variance suggested considerable influence of environment on the expression of genes controlling this trait. The GCV (7.44) and PCV (13.12) were low and moderate (Table 3) that means PCV in general was higher than GCV for the

trait. Wide difference between PCV and GCV for the character, indicating dominant role played by the environment in the expression of the trait and were not desirable for the improvement of this crop. Similar findings for several characters were observed by Narolia (2012) and Singh *et al.* (2002). The heritability estimates for days to first fruiting was low (32.15%) with low genetic advance (5.31%) and genetic advance in percentage of mean (8.69%) (Table 3). Thus indicating that this trait was mostly controlled by both additive and non-additive gene and selection should be delayed to more advance generations for the trait. A genetic advance in percent of mean was low which is in accordance with the findings of Kumar *et al.* (2006).

4.2.4 Days to maturity

The variance due to days to maturity showed that the genotypes differed significantly (Appendix V) and ranged from 89.67 days after transplanting (DAT) in ($G_2 \times G_5$) to 109 DAT in ($G_4 \times G_1$) with mean value 99.61 days after transplanting (DAT) (Appendix VI). The genotypic variance (40.93) was lower than the phenotypic variance (48.25). The GCV (6.42) and PCV (6.97) were also close to each other (both were low), indicating the presence of low variability in this trait (Table 3). The heritability estimates for this trait was very high (84.83%) with moderate genetic advance (12.14%) and genetic advance in percent of mean (12.19%) (Table 3). The heritability of the trait is due to additive gene effects. The high heritability coupled with moderate genetic advance and genetic advance in percent of mean is being exhibited due to the environmental effects and selection should be delayed to more advance generations for the trait. Kumari *et al.* (2007); Mahesha *et al.* (2006); Singh *et al.* (2006); Singh *et al.* (2005); Joshi *et al.* (2004) and Bai and Devi (1991) also found high heritability in his study of tomato.

4.2.5 Plant height (cm)

Significant differences were observed among the genotypes for plant height (Appendix V) which ranged from 72.00 cm ($G_4 \times G_5$) to 99.56 cm ($G_8 \times G_1$) with mean value 87.80 cm (Appendix VI). The genotypic variance and the phenotypic variance were observed 86.70 and 22.58, respectively (Table 3). The PCV (10.61) and GCV of variation (5.41) were moderate and low (Table 3) for plant height. Wide difference between PCV and GCV for the character implies their susceptibility to environmental fluctuation that was

not desirable for the improvement of this crop. Singh *et al.*, 2002 also showed similar result for several characters in his study for tomato. Similar observations were made by Mariane *et al.* (2003); Anandagowda (1997) and Nandapuri *et al.* (1977). The heritability estimates for plant height was low (26.05%) with low genetic advance (5.00%) and genetic advance in percentage of mean (5.69%) (Table 3). Thus indicating that this trait was mostly controlled by non-additive gene and selection would be ineffective. The low heritability of trait may be due to the presence of non-additive type of gene action. Low heritability and low genetic advance was found by Shravan *et al.* (2004) and Aradhana (2003).

4.2.6 Number of branches per plant

The variance due to number of branches per plant showed that the genotypes differed significantly (Appendix V) and ranged from 7.67 in ($G_4 \times G_5$) to 12.00 in ($G_6 \times G_3$, $G_7 \times G_1$) with mean value 9.75 (Appendix VI). The genotypic variance and the phenotypic variance for this trait were 0.50 and 2.20, respectively (Table 3). The phenotypic variance appeared to be higher than the genotypic variance suggested considerable influence of environment on the expression of genes controlling this trait. The GCV (7.26) and PCV (15.22) were low and moderate (Table 3) that means PCV in general was higher than GCV for the trait. Wide difference between PCV and GCV for the character implies their susceptibility to environmental fluctuation that was not desirable for the improvement of this crop. Samadia *et al.*, 2006 and Singh *et al.*, 2002 also showed that the PCV was higher than GCV for several characters in his study. Mohanty *et al.* (2002); Anandagowda (1997) and Bangaru *et al.* (1983) recorded moderate to high variability for this character. The heritability estimates for number of branches per plant was low (22.77%) with low genetic advance (0.70%) and genetic advance in percentage of mean (7.14%) (Table 3). Thus indicating that this trait was mostly controlled by non-additive gene and selection would be ineffective. Genetic advances in percent of mean were low which is in accordance with the findings of Bhuiyan *et al.* (2016). Moderate heritability and low genetic advance for this character was observed by Shravan *et al.* (2004) that was not similar to the present findings.

4.2.7 Number of clusters per plant

The variance due to number of clusters per plant showed that the genotypes differed significantly (Appendix V) and ranged from 15.33 in ($G_4 \times G_8$) to 30.00 in ($G_3 \times G_1$) with mean value 19.97 (Appendix VI). The genotypic variance and the phenotypic variance for this trait were 4.98 and 15.72, respectively (Table 3). The phenotypic variance appeared higher than the genotypic variance suggested influence of environment on the expression of the genes controlling this character. The PCV and GCV were 19.86 and 11.18 respectively (Table 3). The closer GCV and PCV values were observed that indicating minor environmental influence and high degree of genetic variability present on the expression of the character. Thus a greater scope for effective selection exists based upon phenotypic expression of these characters for the improvement of this crop. Similar findings were reported by Farzaneh *et al.* (2013) and Kumari *et al.* (2007). Matin *et al.* (2001) also found similar results in tomato. The heritability estimates low (31.70%) for this trait with low genetic advance (2.59%) and moderate genetic advance in percent of mean (12.97%) (Table 3). The low heritability also coupled with moderate genetic advance in percent of mean is being exhibited due to high environmental effects and selection for this character would take long time. In contrast, high heritability coupled with high genetic advance was obtained by Singh *et al.* (2002) and Kumar *et al.* (1999).

4.2.8 Number of flowers per cluster

Significant differences were observed among the genotypes for number of flowers per cluster (Appendix V) which ranged from 6.00 ($G_1 \times G_7$, $G_2 \times G_4$) and 9.33 ($G_2 \times G_7$, $G_4 \times G_5$) with mean value 7.44 (Appendix VI). The genotypic variance and the phenotypic variance for this trait were 0.23 and 1.41, respectively (Table 3). The phenotypic variance appeared higher than the genotypic variance suggested influence of environment on the expression of the genes controlling this character. The GCV and PCV were (6.42) and (15.95) (Table 3). PCV in general were higher than GCV for all the traits, but wide gap between PCV and GCV for the character indicates more influence of environment on the phenotypic expression. Similar findings for several characters were observed by Narolia

(2012) and Singh *et al.* (2002). The heritability was low (16.22%) for this trait with low genetic advance (0.40%) and low genetic advance in percent of mean (5.33%) (Table 3) indicating that this trait was controlled by non-additive gene and selection for this character would be ineffective. In contrast, high heritability coupled with high genetic advance was obtained by Kumari *et al.* (2007); Mahesha *et al.* (2006); Singh *et al.* (2006); Singh *et al.* (2005); Joshi *et al.* (2004) and Bai and Devi (1991).

4.2.9 Number of fruits per cluster

Significant differences were observed among the genotypes for number of fruits per cluster (Appendix V) which ranged from 4.33 ($G_2 \times G_5$) and 7.33 ($G_6 \times G_5$) with mean value 5.99 (Appendix VI). The genotypic variance and the phenotypic variance for this trait were 0.36 and 0.77. The phenotypic variance appeared to be higher than the genotypic variance suggested that the influence of environment on the expression of the genes controlling this character. The PCV and GCV were 14.66 and 10.07 respectively (Table 3). The closer GCV and PCV values were observed that indicating minor environmental influence and high degree of genetic variability present on the expression of the character. Thus a greater scope for effective selection exists based upon phenotypic expression of these characters for the improvement of this crop. Aradhana and Singh (2003) found moderate PCV and GCV that was similar to the present findings. The heritability estimates for the number of fruits per cluster was moderate (47.20%) with low genetic advance (0.85%) and moderate genetic advance in percentage of mean (14.25%) (Table 3), which suggested that selection should be delayed to more advance generations for this trait. Moderately high heritability coupled with low genetic advance was obtained for the number of fruits per cluster, indicating this trait was mostly controlled by non-additive gene.

4.2.10 Number of fruits per plant

From the current study, significant differences were observed among the genotypes for number of fruits per plant (Appendix V). The minimum was recorded 74.33 in ($G_1 \times G_4$) and the maximum range for number of fruits per plant was 180 found in ($G_3 \times G_1$) with mean value 119.83 (Appendix VI). The genotypic variance and the phenotypic variance

for this trait were 325.50 and 862.21 (Table 3) respectively. The phenotypic variance appeared to be higher than the genotypic variance suggesting that the influence of environment on the expression of the genes controlling this character. The PCV and GCV were 24.50 and 15.06 respectively (Table 3). PCV in general were higher than GCV for all the traits, but wide gap between PCV and GCV for the character indicates more influence of environment on the phenotypic expression. Manivannan *et al.* (2005); Joshi *et al.* (2004); Singh *et al.* (2002) and Brar *et al.* (2000) also showed that the PCV was higher than GCV for several characters in his study. The heritability estimates for this trait was low (37.75%) with high genetic advance (22.84%) and genetic advance in percent of mean (19.04%) (Table 3). The low heritability coupled with high genetic advance and genetic advance in percent of mean is being exhibited due to high environmental effects and selection for this character would be ineffective. High heritability and moderate genetic advance as percent of mean was found by Patil (1996) and Naidu (1993) for this character in their study.

4.2.11 Fruit Length (cm)

Significant differences were observed among the genotypes for this trait (Appendix V). The mean fruit length was noticed as 19.22 cm with a range of 7.67 cm to 36.00 cm. The line (G₆×G₃) showed the minimum fruit length and the maximum fruit length was recorded in the accession (G₂×G₇) (Appendix VI). The genotypic variance and the phenotypic variance were 43.91 and 56.15 and the PCV and GCV were 38.98 and 34.48 respectively (Table 3). The closer GCV and PCV values were observed (Table 3) indicating minor environmental influence and high degree of genetic variability present on the expression of the character. Thus a greater scope for effective selection exists based upon phenotypic expression of these characters for the improvement of this crop. Similar findings were reported by Farzaneh *et al.* (2013) and Kumari *et al.* (2007). Matin *et al.* (2001) also found similar results in tomato. High heritability estimates (78.21%) with moderate genetic advance (12.07%) and high genetic advance over percent of mean (62.81%) was observed for this trait (Table 3), indicating that this trait was mostly controlled by additive gene and selection would be effective. Singh *et al.* (2006); Singh *et al.* (2005) and Joshi *et al.* (2004) also reported similar results.

4.2.12 Fruit Diameter (cm)

Significant differences were observed among the genotypes for this trait (Appendix V). The mean fruit diameter was 21.03 cm with a minimum range of 13.33 cm ($G_1 \times G_6$) to 48.00 cm ($G_1 \times G_4$) (Appendix VI). The phenotypic variance and the genotypic variance were (54.02 and 43.10 respectively). The phenotypic variance appeared to be higher than the genotypic variance suggesting that the influence of environment on the expression of the genes controlling this character and GCV (31.21) and PCV (34.95) (Table 3) were close to each other, indicating minor environmental influence on this character that would be effective for the improvement of tomato. High heritability estimates (79.78%) with moderate genetic advance (12.08%) and high genetic advance over percent of mean (57.43%) (Table 3), indicating that this trait was mostly controlled by additive gene and selection would be effective. Singh *et al.* (2006); Singh *et al.* (2005) and Joshi *et al.* (2004) also reported similar results.

4.2.13 Skin diameter (mm)

The variance due to skin diameter showed that the genotypes differed significantly (Appendix V) and ranged from 2.9 mm in ($G_7 \times G_6$) to 6.17 mm in ($G_1 \times G_3$) with mean value 4.40 mm (Appendix VI). The genotypic variance and the phenotypic variance for this trait were 0.44 and 0.63 respectively (Table 3). The phenotypic variance appeared to be higher than the genotypic variance suggested considerable influence of environment on the expression of genes controlling this trait. The GCV (15.08) and PCV (18.04) were more or less similar to each other (Table 3). Moderate PCV and GCV were estimated for the trait, implying equal importance of additive and non-additive gene action. Moderate PCV and GCV were also found by Saeed *et al.* (2007); Joshi *et al.* (2004); Aradhana and Singh (2003); and Singh *et al.* (2002). The heritability estimates for skin diameter was moderate (69.91%) with low genetic advance (1.14%) and high genetic advance in percentage of mean (25.98%) (Table 3), which suggested that selection should be delayed to more advance generations for these traits. Genetic advances in percent of mean were high which is in accordance with the findings of Singh *et al.* (1973).

4.2.14 Locule number

The variance due to locule number showed that the genotypes differed significantly (Appendix V) and ranged from 2.00 in ($G_1 \times G_7$, $G_2 \times G_5$, $G_3 \times G_1$, $G_5 \times G_6$, $G_5 \times G_8$, $G_7 \times G_3$) to 8.67 in ($G_1 \times G_4$) with mean value 3.03 (Appendix VI). The genotypic variance and the phenotypic variance for this trait were 1.48 and 1.80, respectively (Table 3). The phenotypic variance appeared to be higher than the genotypic variance suggested considerable influence of environment on the expression of genes controlling this trait. The GCV (40.05) and PCV (44.19) were more or less similar to each other, indicating minor environmental influence and high degree of genetic variability present on the expression of the character (Table 3). Thus a greater scope for effective selection exists based upon phenotypic expression of these characters for the improvement of this crop. Similar findings were reported by Farzaneh *et al.* (2013) and Kumari *et al.* (2007). Matin *et al.* (2001) also found similar results in tomato. The heritability estimates for locule number was high (82.11%) with low genetic advance (2.27%) and high genetic advance in percentage of mean (74.75%) (Table 3). Thus indicating that this trait was mostly controlled by additive gene and selection would be effective. Singh *et al.* (2006); Singh *et al.* (2005) and Joshi *et al.* (2004) also reported similar results.

4.2.15 Total soluble solids

The variance due to total soluble solids showed that the genotypes differed significantly (Appendix V) and ranged from 1.00 in ($G_1 \times G_3$, $G_1 \times G_4$, $G_2 \times G_1$, $G_2 \times G_5$, $G_3 \times G_2$, $G_4 \times G_5$, $G_6 \times G_7$, $G_7 \times G_3$) to 6.37 in ($G_1 \times G_5$) with mean value 2.60 (Appendix VI). The genotypic variance and the phenotypic variance for this trait were 1.907 and 1.910 respectively (Table 3). The phenotypic variance appeared to be higher than the genotypic variance suggested considerable influence of environment on the expression of genes controlling this trait. The GCV (53.09) and PCV (53.12) were more or less similar to each other, indicated presence of high variability in this trait (Table 3). Bhuiyan *et al.* (2016) reported the same result for the parameter individual fruit weight, fruit length and number of fruit per plant. The heritability estimates for total soluble solids was high (99.87%) with low genetic advance (2.84%) and high genetic advance in percentage of mean

(109.28%) (Table 3). Thus indicating that this trait was mostly controlled by additive gene and selection would be effective. Mahesha *et al.* (2006); Singh *et al.* (2006); Singh *et al.* (2005) and Joshi *et al.* (2004) also reported similar results.

4.2.16 P^H

The variance due to P^H showed that the genotypes differed significantly (Appendix V) and ranged from 3.65 in (G₁×G₄, G₇×G₁, G₇×G₆) to 6.55 in (G₁×G₇) with mean value 4.49 (Appendix VI). The genotypic variance and the phenotypic variance for this trait were 0.233 and 0.235, respectively (Table 3). The phenotypic variance appeared to be higher than the genotypic variance suggested considerable influence of environment on the expression of genes controlling this trait. The GCV (10.77) and PCV (10.81) were more or less similar to each other (Table 3). Moderate PCV and GCV were estimated for the trait, implying equal importance of additive and non-additive gene action. Moderate PCV and GCV were also found by Saeed *et al.* (2007); Joshi *et al.* (2004); Aradhana and Singh (2003); and Singh *et al.* (2002). The heritability estimates for P^H was high (99.24%) with low genetic advance (0.99%) and high genetic advance in percentage of mean (22.10%) (Table 3). Thus indicating that this trait was mostly controlled by additive gene and selection would be effective. Singh *et al.* (2006); Singh *et al.* (2005) and Joshi *et al.* (2004) also reported similar results.

4.2.17 Relative water content

The variance due to relative water content showed that the genotypes differed significantly (Appendix V) and ranged from 52.31 g in (G₂×G₃) to 88.79 g in (G₆×G₂) with mean value 75.94 (Appendix VI). The genotypic variance and the phenotypic variance for this trait were 100.07 and 105.98, respectively (Table 3). The phenotypic variance appeared to be higher than the genotypic variance suggested considerable influence of environment on the expression of genes controlling this trait. The GCV (13.17) and PCV (13.56) were more or less similar to each other (Table 3). Moderate PCV and GCV were found for the trait, implying the equal importance of additive and non-additive gene action. Moderate PCV and GCV were also found by Saeed *et al.* (2007) and Joshi *et al.* (2004). The heritability estimates for relative water content was

high (94.43%) with high genetic advance (20.02%) and genetic advance in percentage of mean (26.37%) (Table 3). High heritability coupled with high genetic advance in percentage of mean was obtained that suggesting this trait was highly heritable and there is a wide scope for improvement through selection of this trait. Most likely the heritability of this trait is due to additive gene effects and selection may be effective in early generations for this trait. Kumar *et al.* (2007); Mahesha *et al.* (2006); Singh *et al.* (2006); Joshi *et al.* (2004); Islam and Khan (1991); Bai and Devi (1991) also reported high heritability for different yield controlling traits in tomato.

4.2.18 Moisture Percentage

The variance due to moisture percentage showed that the genotypes differed significantly (Appendix V) and ranged from 94.62 g in ($G_1 \times G_4$, $G_6 \times G_7$) to 99.98 g in ($G_1 \times G_5$, $G_1 \times G_6$, $G_4 \times G_3$, $G_4 \times G_6$, $G_4 \times G_7$, $G_4 \times G_8$, $G_5 \times G_6$, $G_6 \times G_3$, $G_7 \times G_8$) with mean value 97.94 g (Appendix VI). The genotypic variance and the phenotypic variance for this trait were 3.13 and 3.38, respectively (Table 3). The phenotypic variance appeared to be higher than the genotypic variance suggested considerable influence of environment on the expression of genes controlling this trait. The GCV (1.81) and PCV (1.88) were more or less similar to each other (both were low), indicated presence of low variability in this trait (Table 3) which is same as the findings of Bhuiyan *et al.* (2016) and Singh *et al.* (2002). The heritability estimates for moisture percentage was high (92.52%) with low genetic advance (3.51%) and genetic advance in percentage of mean (3.58%) (Table 3). Thus indicating that this trait was mostly controlled by both additive and non-additive gene and selection would be ineffective. A genetic advance in per cent of mean was low which is in accordance with the findings of Kumar *et al.* (2006).

4.2.19 Individual Fruit weight (g)

The variance due to individual fruit weight showed that the genotypes differed significantly (Appendix V) and ranged from 13.53 g in ($G_4 \times G_2$) to 61 g in ($G_2 \times G_1$, $G_1 \times G_4$) with mean value 27.99 g (Appendix VI). The genotypic variance and the phenotypic variance for this trait were 125.75 and 126.27, respectively (Table 3). The phenotypic variance appeared to be higher than the genotypic variance suggested

considerable influence of environment on the expression of genes controlling this trait. The GCV (40.06) and PCV (40.14) were more or less similar to each other, indicated presence of high variability in this trait (Table 3). Thus a greater scope for effective selection exists based upon phenotypic expression of these characters for the improvement of this crop. Similar findings were reported by Farzaneh *et al.* (2013); Kumari *et al.* (2007) and Parvindar *et al.* (2002). Similar result was found by Bhuiyan *et al.* (2016) for the same character. The heritability estimates for individual Fruit weight was high (99.59%) with high genetic advance (23.05%) and genetic advance in percentage of mean (82.36%) (Table 3). High heritability coupled with high genetic advance in percentage of mean was obtained that suggesting this trait was highly heritable and there is a wide scope for improvement through selection of this trait. Most likely the heritability of this trait is due to additive gene effects and selection may be effective in early generations for this trait. The findings is similar to the findings of Bhuiyan *et al.* (2016); Pandit *et al.* (2010); Kumari *et al.* (2007); Ara *et al.* (2009); Mahesha *et al.* (2006); Singh *et al.* (2006); Singh *et al.* (2005); Joshi *et al.* (2004) and Bai and Devi (1991).

4.2.20 Yield per plant (kg)

The variance due to yield per plant showed that the genotypes differed significantly (Appendix V) and ranged from 1.54 kg in ($G_5 \times G_3$) to 4.62 kg in ($G_1 \times G_4$, $G_2 \times G_1$) with mean value 3.19 (Appendix VI). The genotypic variance and the phenotypic variance for this trait were 0.66 and 0.96, respectively (Table 3). The phenotypic variance appeared to be higher than the genotypic variance suggested considerable influence of environment on the expression of genes controlling this trait. The GCV and PCV were 25.43 and 30.73 respectively (Table 3), indicating that minor environmental influence and high degree of genetic variability present on the expression of these characters. Thus a greater scope for effective selection exists based upon phenotypic expression of these characters for the improvement of this crop. Similar findings were reported by Farzaneh *et al.* (2013); Kumari *et al.* (2007); Manivannan *et al.* (2005); Anupam *et al.* (2002) and Malin *et al.* (2001). The heritability estimates for yield per plant was moderately high (78.49%) with low genetic advance (1.38%) and high genetic advance in percentage of mean (43.36%)

(Table 3). Thus indicating that this trait was mostly controlled by additive gene and selection would be effective. Mahesha *et al.* (2006); Singh *et al.* (2006); Singh *et al.* (2005), Joshi *et al.* (2004); Mariane *et al.* (2003) and Bai and Devi (1991) also reported similar results.

4.3 Correlation Co-efficient

Correlation studies along with path analysis provide a better understanding of the association of different characters with fruit yield. Simple correlation was partitioned into phenotypic (that can be directly observed), genotypic (inherent association between characters) components as suggested by (Singh and Chaudhary, 1985). As we know yield is a complex product being influenced by several inter-dependable quantitative characters. So selection may not be effective unless the other contributing components are not considered. When selection pressure is applied for improvement of any character highly associated with yield, it simultaneously affects a number of other correlated characters. Hence knowledge regarding association of character with yield and among themselves provides guideline to the plant breeders for making improvement through selection with a clear understanding about the contribution in respect of establishing the association by genetic and non-genetic factors (Dewey and Lu, 1959). The genotypic correlation coefficients in most cases were higher than their phenotypic correlation coefficients indicating the genetic reason of association. While phenotypic correlation coefficient were higher than genotypic correlation coefficient indicating suppressing effect of the environment which modified the expression of the characters at phenotypic level. The depicted of genotypic and phenotypic correlation coefficients among different pairs of yield and yield contributing characters for different genotypes of tomato are given in (Table 4).

4.3.1 Days to first flowering

Days to first flowering had significant positive correlation with days to 50% flowering ($r_g=0.416$), days to first fruiting ($r_p=0.389$), days to maturity ($r_g=0.520$, $r_p=0.229$), number of fruits per cluster ($r_g=0.406$), number of fruits per plant ($r_g=0.428$), skin diameter

($r_g=0.271$), total soluble solids ($r_g=0.279$), relative water content ($r_g=0.461$, $r_p=0.232$) and moisture percentage ($r_g=0.342$, $r_p=0.200$) (Table 4). Samadia *et al.* (2006); Mayavel *et al.* (2005); Patil and Bojappa (1993), observed positive correlation which supports the present findings. It had negatively significant correlation with fruit length ($r_g=-0.254$), individual fruit weight ($r_g=-0.262$) and fruit yield per plant ($r_g=-0.260$, $r_p=-0.209$). A negative correlation between days to first flowering and yield per plant was observed by Akhter (2021) and Islam (2012) at both genotypic and phenotypic level. Days to first flowering had positive but non-significant correlation with days to 50% flowering ($r_p=0.175$), days to first fruiting ($r_g=0.125$), plant height ($r_g=0.174$), number of branches per plant ($r_g=0.152$, $r_p=0.023$), number of clusters per plant ($r_g=0.118$), number of fruits per cluster ($r_p=0.042$), number of fruits per plant ($r_p=0.012$), fruit diameter ($r_g=0.037$), skin diameter ($r_p=0.125$), locule number ($r_g=0.179$, $r_p=0.043$) and total soluble solids ($r_p=0.140$). This trait had non-significant negative correlation for plant height ($r_p=-0.109$), number of clusters per plant ($r_p=-0.029$), number of flowers per cluster ($r_g=-0.121$, $r_p=-0.034$), fruit length ($r_p=-0.135$), fruit diameter ($r_p=-0.010$), pH ($r_g=-0.128$, $r_p=-0.061$) and individual fruit weight ($r_p=-0.136$).

4.3.2 Days to 50% flowering

Days to 50% flowering had significant positive correlation with days to first fruiting ($r_g=0.534$, $r_p=0.247$), days to maturity ($r_g=0.801$, $r_p=0.678$), plant height ($r_g=0.492$, $r_p=0.192$), number of branches per plant ($r_g=0.333$), number of cluster per plant ($r_g=0.429$, $r_p=0.207$), number of fruits per cluster ($r_g=0.214$), number of fruits per plant ($r_g=0.485$, $r_p=0.239$), total soluble solids ($r_g=0.596$, $r_p=0.544$), and moisture percentage ($r_g=0.233$, $r_p=0.199$) (Table 4). Dhankhar and Dhankhar (2006); Samadia *et al.* (2006) and Mayavel *et al.* (2005), observed positive correlation which supports the present findings. It had negatively significant correlation with number of flowers per cluster ($r_g=-0.291$), fruit length ($r_g=-0.676$, $r_p=-0.545$), fruit diameter ($r_g=-0.497$, $r_p=-0.417$), locule number ($r_g=-0.235$), individual fruit weight ($r_g=-0.525$, $r_p=-0.476$) and yield per plant ($r_g=-0.505$, $r_p=-0.412$). A negative correlation between days to 50% flowering and yield per plant was observed by Islam (2012) that was not significant. Days to 50% flowering

Table 4. Genotypic and Phenotypic correlation coefficients among different pairs of yield and yield contributing characters for 39 genotypes

Characters		DFF	DFFP	DFFr	DM	PH	NBP	NCP	NFC	NfrC	NFrP	FL	FD	SD	LN	TSS	pH	RWC	MP	IFrW	
DFFP	r _g	0.416**																			
	r _p	0.175ns																			
DFFr	r _g	0.125ns	0.534**																		
	r _p	0.389**	0.247**																		
DM	r _g	0.520**	0.801**	0.523**																	
	r _p	0.229*	0.678**	0.294**																	
PH	r _g	0.174 ns	0.492**	0.394**	0.419**																
	r _p	-0.109ns	0.192*	0.072ns	0.225*																
NBP	r _g	0.152ns	0.333**	0.045ns	0.386**	0.015ns															
	r _p	0.023ns	0.102ns	0.148ns	0.185*	0.355**															
NCP	r _g	0.118ns	0.429**	0.388**	0.621**	0.152ns	0.072ns														
	r _p	-0.029ns	0.207*	0.044ns	0.250**	0.212*	0.160ns														
NFC	r _g	-0.121ns	-0.291**	-0.011ns	-0.030ns	-0.205*	0.225*	0.277**													
	r _p	-0.034ns	-0.175ns	-0.027ns	-0.034ns	-0.184*	-0.172ns	-0.029ns													
NfrC	r _g	0.406**	0.214*	0.356**	0.308**	0.228*	0.567**	0.071ns	0.130ns												
	r _p	0.042ns	0.103ns	0.093ns	0.164ns	0.105ns	0.054ns	-0.045ns	0.495**												
NFrP	r _g	0.428**	0.485**	0.575**	0.692**	0.241**	0.344**	0.788**	0.276**	0.656**											
	r _p	0.012ns	0.239**	0.095ns	0.312**	0.237*	0.152ns	0.818**	0.260**	0.522**											
FL	r _g	-0.254**	-0.676**	-0.213*	-0.651**	-0.530**	-0.476**	-0.651**	0.516**	-0.259**	-0.690**										
	r _p	-0.135ns	-0.545**	-0.131ns	-0.550**	-0.196*	-0.191*	-0.305**	0.208*	-0.111ns	-0.333**										
FD	r _g	0.037ns	-0.497**	-0.361**	-0.469**	-0.791**	-0.312**	-0.579**	0.177ns	-0.301**	-0.616**	0.570**									
	r _p	-0.010ns	-0.417**	-0.192*	-0.369**	-0.339**	-0.110ns	-0.290**	0.016ns	-0.221*	-0.348**	0.533**									
SD	r _g	0.271**	-0.091ns	0.132ns	-0.011ns	-0.163ns	-0.061ns	-0.541**	0.030ns	0.133ns	-0.282**	0.449**	0.401**								
	r _p	0.125ns	-0.099ns	0.064ns	-0.002ns	-0.152ns	-0.029ns	-0.259**	0.013ns	0.033ns	-0.189*	0.356**	0.292**								
LN	r _g	0.179ns	-0.235*	-0.504**	-0.253**	-0.522**	-0.317**	-0.381**	-0.258**	-0.460**	-0.552**	0.130ns	0.778**	0.198*							
	r _p	0.043ns	-0.177ns	-0.263**	-0.196*	-0.273**	-0.197*	-0.219*	-0.017ns	-0.209*	-0.286**	0.122ns	0.624**	0.072ns							
TSS	r _g	0.279**	0.596**	0.395**	0.454**	0.442**	0.378**	0.403**	-0.412**	0.203*	0.453**	-0.633**	-0.580**	-0.148ns	-0.404**						
	r _p	0.140ns	0.544**	0.226*	0.417**	0.228*	0.179ns	0.230*	-0.168ns	0.158ns	0.280**	-0.561**	-0.517**	-0.123ns	-0.366**						
pH	r _g	-0.128ns	-0.029ns	-0.147ns	-0.028ns	0.271**	-0.071ns	-0.089ns	-0.501**	-0.139ns	-0.157ns	0.002ns	-0.184*	0.106ns	-0.295**	-0.039ns					
	r _p	-0.061ns	-0.026ns	-0.078ns	-0.020ns	0.136ns	-0.027ns	-0.050ns	-0.205*	0.100ns	-0.099ns	-0.005ns	-0.171ns	0.086ns	-0.265**	-0.038ns					
RWC	r _g	0.461**	0.107ns	0.243**	0.151ns	0.184*	-0.398**	-0.041ns	0.455**	0.064ns	0.043ns	0.137ns	-0.142ns	0.085ns	-0.182*	0.123ns	-0.141ns				
	r _p	0.232*	0.082ns	0.153ns	0.151ns	0.130ns	-0.127ns	-0.015ns	0.149ns	0.005ns	0.009ns	0.117ns	-0.107ns	0.052ns	-0.149ns	0.120ns	-0.135ns				
MP	r _g	0.342**	0.233*	0.359**	0.547**	0.225*	0.540**	0.341**	0.190*	0.481**	0.547**	-0.406**	-0.458**	-0.097ns	-0.288**	0.336**	-0.085ns	0.266**			
	r _p	0.200*	0.199*	0.210*	0.471**	0.124ns	0.220*	0.194*	0.050ns	0.296ns	0.318**	-0.357**	-0.398**	-0.087ns	-0.257**	0.323**	-0.082ns	0.238**			
IFrW	r _g	-0.262**	-0.525**	-0.580**	-0.634**	-0.688**	-0.645**	-0.629**	0.115ns	-0.560**	-0.812**	0.663**	0.699**	0.268**	0.593**	-0.668**	-0.074ns	0.036ns	-0.543**		
	r _p	-0.136ns	-0.476**	-0.334**	-0.584**	-0.348**	-0.307**	-0.356**	0.045ns	-0.380**	-0.497**	0.595**	0.621**	0.219*	0.544**	-0.666**	-0.073ns	0.035ns	-0.521**		
YP	r _g	-0.260**	-0.505**	-0.493**	-0.539**	-0.748**	-0.712**	-0.384**	0.403**	-0.304**	-0.478**	0.567**	0.484**	0.222*	0.407**	-0.719**	-0.107ns	0.030ns	-0.440**	0.875**	
	r _p	-0.209*	-0.412**	-0.308**	-0.460**	-0.249**	-0.247**	0.122ns	0.323**	0.045ns	0.158ns	0.453**	0.349**	0.123ns	0.338**	-0.592**	-0.090ns	0.008ns	-0.364**	0.728**	

** = Significant at 1%. * = Significant at 5%. ns = Non-significant.

Note: DFF= Days to first flowering, DFFP= Days to 50% flowering, DFFr= Days to first fruiting, DM= Days to maturity, PH= Plant height (cm), NBP= No. of branches per plant, NCP= No. of clusters per plant, NFC= No. of flowers per cluster, NfrC= No. of fruits per cluster, NFrP= No. of fruits per plant, FL= Fruit length (cm), FD= Fruit diameter (cm), SD= Skin diameter (mm), LN= Locule number, TSS= Total soluble solid, pH, RWC= Relative water content, MP= Moisture percentage, IFrW= Individual fruit weight (g), YP= Yield per plant (kg).

had positive but non-significant correlation with number of branches per plant ($r_p=0.102$), number of fruits per cluster ($r_p=0.103$) and relative water content ($r_g=0.107$, $r_p=0.082$). This trait had non-significant negative correlation for number of flowers per cluster ($r_p=-0.175$), skin diameter ($r_g=-0.091$, $r_p=-0.099$), locule number ($r_p=-0.177$) and pH ($r_g=-0.029$, $r_p=-0.026$).

4.3.3 Days to first fruiting

Days to first fruiting had significant positive correlation with days to maturity ($r_g=0.523$, $r_p=0.294$), plant height ($r_g=0.394$), number of clusters per plant ($r_g=0.388$), number of fruits per cluster ($r_g=0.356$), number of fruits per plant ($r_g=0.575$), total soluble solids ($r_g=0.395$, $r_p=0.226$), relative water content ($r_g=0.243$) and moisture percentage ($r_g=0.359$, $r_p=0.210$) (Table 4). Samadia *et al.* (2006); Mayavel *et al.* (2005); Patil and Bojappa (1993), observed positive correlation which supports the present findings. It had negatively significant correlation with number of fruits per cluster ($r_g=-0.295$), fruit length ($r_g=-0.218$), fruit diameter ($r_g=-0.361$, $r_p=-0.192$), locule number ($r_g=-0.504$, $r_p=-0.263$), individual fruit weight ($r_g=-0.580$, $r_p=-0.334$) and yield per plant ($r_g=-0.493$, $r_p=-0.308$). Days to first fruiting had positive but non-significant correlation with plant height ($r_p=0.072$), number of branches per plant ($r_g=0.045$, $r_p=0.148$), number of clusters per plant ($r_p=0.044$), number of fruits per cluster ($r_p=0.093$), number of fruits per plant ($r_p=0.095$), skin diameter ($r_g=0.132$, $r_p=0.064$) and relative water content ($r_p=0.153$). This trait had non-significant negative correlation for number of flowers per cluster ($r_g=-0.011$, $r_p=-0.027$), fruit length ($r_p=-0.131$) and pH ($r_g=-0.147$, $r_p=-0.078$).

4.3.4 Days to maturity

Days to maturity had highly significant positive correlation with plant height ($r_g=0.419$, $r_p=0.225$), number of branches per plant ($r_g=0.386$, $r_p=0.185$), number of clusters per plant ($r_g=0.621$, $r_p=0.250$), number of fruits per cluster ($r_g=0.308$), number of fruits per plant ($r_g=0.692$, $r_p=0.312$), total soluble solids ($r_g=0.454$, $r_p=0.417$) and moisture percentage ($r_g=0.547$, $r_p=0.471$) (Table 4). It had negatively significant correlation with fruit length ($r_g=-0.651$, $r_p=-0.550$), fruit diameter ($r_g=-0.469$, $r_p=-0.369$), locule number

($r_g=-0.253$, $r_p=-0.196$) individual fruit weight ($r_g=-0.634$, $r_p=-0.584$) and yield per plant ($r_g=-0.539$, $r_p=-0.460$). A significant and positive correlation observed by Mohanty *et al.* (2003) and Singh *et al.* (2002) between days to maturity and fruit yield per plant and this does not support the present findings. It had also non-significant negative correlation with number of flowers per cluster ($r_g=-0.030$, $r_p=-0.034$), skin diameter ($r_g=-0.011$, $r_p=-0.002$) and pH ($r_g=-0.028$, $r_p=-0.020$). Days to maturity had positive non-significant association with number of fruits per cluster ($r_p=0.164$) and relative water content ($r_g=0.151$, $r_p=0.151$).

4.3.5 Plant height

Plant height had significant positive correlation with number of branches per plant ($r_p=0.355$), number of clusters per plant ($r_p=0.212$), number of fruits per cluster ($r_g=0.228$), number of fruits per plant ($r_g=0.241$, $r_p=0.237$), total soluble solids ($r_g=0.442$, $r_p=0.228$), pH ($r_g=0.271$), relative water content ($r_g=0.184$) and moisture percentage ($r_g=0.225$) (Table 4). It had negatively significant correlation with number of flowers per cluster ($r_g=-0.205$, $r_p=-0.184$), fruit length ($r_g=-0.530$, $r_p=-0.196$), fruit diameter ($r_g=-0.791$, $r_p=-0.339$), locule number ($r_g=-0.522$, $r_p=-0.273$), individual fruit weight ($r_g=-0.688$, $r_p=-0.348$) and fruit yield per plant ($r_g=-0.748$, $r_p=-0.249$). A negative correlation between plant height and yield per plant was observed by Akhter (2021); Dhankhar and Dhankhar (2006) and Mohanty (2003). Plant height had also non-significant positive correlation with number of branches per plant ($r_g=0.015$), number of clusters per plant ($r_g=0.152$), number of fruits per cluster ($r_p=0.105$), pH ($r_p=0.136$), relative water content ($r_p=0.130$) and moisture percentage ($r_p=0.124$). It had non-significant negative correlation with skin diameter ($r_g=-0.163$, $r_p=-0.152$).

4.3.6 Number of branches per plant

The number of branches per plant had significant and positive association with number of flowers per cluster ($r_g=0.225$), number of fruits per cluster ($r_g=0.567$), number of fruits per plant ($r_g=0.344$), total soluble solids ($r_g=0.378$) and moisture percentage ($r_g=0.540$, $r_p=0.220$) (Table 4). Number of branches per plant had significant and negative

association with fruit length ($r_g=-0.476$, $r_p=-0.191$), fruit diameter ($r_g=-0.312$), locule number ($r_g=-0.317$, $r_p=-0.197$), relative water content ($r_g=-0.398$), individual fruit weight ($r_g=-0.645$, $r_p=-0.307$) and fruit yield per plant ($r_g=-0.712$, $r_p=-0.247$). A positive correlation between number of branches per plant and fruit yield per plant was observed by Monamodi *et al.* (2013); Prasanth (2008) and Nesgea *et al.* (2002) and this does not support the present findings. A negative correlation between number of branches per plant and yield per plant was observed by Islam (2012) and Singh *et al.* (2005). Number of branches per plant had non-significant positive association with number of clusters per plant ($r_g=0.072$, $r_p=0.160$), number of fruits per cluster ($r_p=0.054$), number of fruit per plant ($r_p=0.152$) and total soluble solids ($r_p=0.179$). It also had non-significant negative association with number of flowers per cluster ($r_p=-0.172$), fruit diameter ($r_p=-0.110$), skin diameter ($r_g=-0.061$, $r_p=-0.029$), pH ($r_g=-0.071$, $r_p=-0.027$) and relative water content ($r_p=-0.127$).

4.3.7 Number of clusters per plant

The number of clusters per plant had significant and positive association with number of flowers per cluster ($r_g=0.277$), number of fruits per plant ($r_g=0.788$, $r_p=0.818$), total soluble solids ($r_g=0.403$, $r_p=0.230$) and moisture percentage ($r_g=0.341$, $r_p=0.194$) (Table 4). A positive correlation between number of clusters per plant and fruit yield per plant was also observed by Akhter (2021); Prasanth (2008) and Nesgea *et al.* (2002). Number of clusters per plant had significant and negative correlation with fruit length ($r_g=-0.651$, $r_p=-0.305$), fruit diameter ($r_g=-0.579$, $r_p=-0.290$), skin diameter ($r_g=-0.541$, $r_p=-0.259$), locule number ($r_g=-0.381$, $r_p=-0.219$), individual fruit weight ($r_g=-0.629$, $r_p=-0.356$) and fruit yield per plant ($r_g=-0.384$). A negative correlation between number of clusters per plant and yield per plant was observed by Islam (2012) in his study at both genotypic and phenotypic level. Number of clusters per plant had non-significant positive association with number of fruits per cluster ($r_g=0.071$) and fruit yield per plant ($r_p=0.122$). It also had non-significant negative association with number of flowers per cluster ($r_p=-0.029$), number of fruits per cluster ($r_p=-0.045$), pH ($r_g=-0.089$, $r_p=-0.050$) and relative water content ($r_g=-0.041$, $r_p=-0.015$).

4.3.8 Number of flowers per cluster

The number of flowers per cluster had highly significant and positive correlation with number of fruits per cluster ($r_p=0.495$), number of fruits per plant ($r_g=0.276$, $r_p=0.260$), fruit length ($r_g=0.516$, $r_p=0.208$), relative water content ($r_g=0.455$), moisture percentage ($r_g=0.190$) and fruit yield per plant ($r_g=0.403$, $r_p=0.323$) (Table 4). The number of flowers per cluster showed significant but negative association with locule number ($r_g=-0.258$), total soluble solids ($r_g=-0.412$), pH ($r_g=-0.511$, $r_p=-0.205$). It had non-significant and positive correlation with number of fruits per cluster ($r_g=0.130$), fruit diameter ($r_g=0.177$, $r_p=0.016$), skin diameter ($r_g=0.030$, $r_p=0.013$), relative water content ($r_p=0.149$), moisture percentage ($r_p=0.050$) and individual fruit weight ($r_g=0.115$, $r_p=0.045$). It also exhibited non-significant negative association with locule number ($r_p=-0.017$) and total soluble solids ($r_p=-0.168$). The findings also supported by Nesgea *et al.* (2002) and Megha *et al.* (2006).

4.3.9 Number of fruits per cluster

The number of fruits per cluster had highly significant and positive association with number of fruits per plant ($r_g=0.656$, $r_p=0.522$), total soluble solids ($r_g=0.203$) and moisture percentage ($r_g=0.481$) (Table 4). This trait has negatively significant association with fruit length ($r_g=-0.259$), fruit diameter ($r_g=-0.301$, $r_p=-0.221$), locule number ($r_g=-0.460$, $r_p=-0.209$), individual fruit weight ($r_g=-0.560$, $r_p=-0.380$) and fruit yield per plant ($r_g=-0.304$). A negative correlation between number of fruits per cluster and yield per plant was observed by Islam (2012) in his study at both genotypic and phenotypic level. It had also positive non-significant correlation with skin diameter ($r_g=0.133$, $r_g=0.033$), total soluble solids ($r_p=0.158$), pH ($r_p=0.100$), relative water content ($r_g=0.064$, $r_p=0.005$), moisture percentage ($r_p=0.296$) and fruit yield per plant ($r_p=0.045$). It also exhibited non-significant negative association with fruit length ($r_p=-0.111$) and pH ($r_g=-0.139$). Naidu *et al.* (2002) and Megha *et al.* (2006) revealed that plant height, number of branches per plant, number of fruits per cluster should be considered for the enhancement of the yield of tomato.

4.3.10 Number of fruits per plant

The number of fruits per plant had significant and positive association with total soluble solids ($r_g=0.453$, $r_p=0.280$) and moisture percentage ($r_g=0.547$, $r_p=0.318$), respectively (Table 4). It had also significant negative correlation with fruit length ($r_g=-0.690$, $r_p=-0.333$), fruit diameter ($r_g=-0.616$, $r_p=-0.348$), skin diameter ($r_g=-0.282$, $r_p=-0.189$), locule number ($r_g=-0.552$, $r_p=-0.286$), individual fruit weight ($r_g=-0.812$, $r_p=-0.497$) and fruit yield per plant ($r_g=-0.478$). Rani *et al.* (2010) and Rath *et al.* (2001) also reported that the number of fruits per plant was negatively associated with yield per plant. It had non-significant and positive correlation with relative water content ($r_g=0.043$, $r_p=0.009$), fruit yield per plant ($r_p=0.158$) and negative association with pH ($r_g=-0.157$, $r_p=-0.099$).

4.3.11 Fruit length (mm)

Fruit length was significantly positively correlated with fruit diameter ($r_g=0.570$, $r_p=0.533$), skin diameter ($r_g=0.449$, $r_p=0.356$), individual fruit weight ($r_g=0.663$, $r_p=0.595$), fruit yield per plant ($r_g=0.567$, $r_p=0.453$) and non-significant positive correlation with locule number ($r_g=0.130$, $r_p=0.122$), pH ($r_g=0.002$), relative water content ($r_g=0.137$, $r_p=0.117$) (Table 4). Golani *et al.* (2007) observed that fruit weight had significant and positive correlation with fruit length at both levels. Fruit length also showed significantly negative correlation with total soluble solids ($r_g=-0.631$, $r_p=-0.561$), moisture percentage ($r_g=-0.406$, $r_p=-0.357$) and non-significantly negative correlation with pH ($r_p=-0.005$).

4.3.12 Fruit diameter (mm)

Fruit diameter showed significant and positive correlation with skin diameter ($r_g=0.401$, $r_p=0.292$), locule number ($r_g=0.778$, $r_p=0.624$), individual fruit weight ($r_g=0.699$, $r_p=0.621$) and fruit yield per plant ($r_g=0.484$, $r_p=0.349$) but significantly negative correlation with total soluble solids ($r_g=-0.580$, $r_p=-0.517$), pH ($r_g=-0.184$) and moisture percentage ($r_g=-0.458$, $r_p=-0.398$) (Table 4). It had also non-significant and negative association with pH ($r_p=-0.171$) and relative water content ($r_g=-0.142$, $r_p=-0.107$).

4.3.13 Skin diameter (mm)

Skin diameter showed significant and positive correlation with locule number ($r_g=0.198$), individual fruit weight ($r_g=0.268$, $r_p=0.219$) and fruit yield per plant ($r_g=0.222$) (Table 4). It had also non-significantly positive association with locule number ($r_p=0.072$), pH ($r_g=0.106$, $r_p=0.086$), relative water content ($r_g=0.085$, $r_p=0.052$), fruit yield per plant ($r_p=0.123$) and non-significantly negative association with total soluble solids ($r_g=-0.148$, $r_p=-0.123$), moisture percentage ($r_g=-0.097$, $r_p=-0.087$).

4.3.14 Locule number

Locule number showed significantly positive association with individual fruit weight ($r_g=0.598$, $r_p=0.544$), fruit yield per plant ($r_g=0.407$, $r_p=0.338$) and significantly negative association with total soluble solids ($r_g=-0.404$, $r_p=-0.366$), pH ($r_g=-0.295$, $r_p=-0.265$), relative water content ($r_g=-0.182$) and moisture percentage ($r_g=-0.288$, $r_p=-0.257$) (Table 4). It had also non-significantly negative association with relative water content ($r_p=-0.149$).

4.3.15 Total soluble solids

Total soluble solids showed significantly positive association with moisture percentage ($r_g=0.336$, $r_p=0.323$) and significantly negative relation with individual fruit weight ($r_g=-0.668$, $r_p=-0.666$) and fruit yield per plant ($r_g=-0.719$, $r_p=-0.592$) (Table 4). It had also non-significantly negative association with pH ($r_g=-0.039$, $r_p=-0.038$) and positive association with relative water content ($r_g=0.123$, $r_p=0.120$).

4.3.16 pH

pH had non-significantly negative association with relative water content ($r_g=-0.141$, $r_p=-0.135$), moisture percentage ($r_g=-0.085$, $r_p=-0.082$), individual fruit weight ($r_g=-0.074$, $r_p=-0.073$) and fruit yield per plant ($r_g=-0.107$, $r_p=-0.090$) (Table 4).

4.3.17 Relative water content

Relative water content showed significantly positive association with moisture percentage ($r_g=0.266$, $r_p=0.238$). Relative water content showed non-significantly

positive relation with individual fruit weight ($r_g=0.036$, $r_p=0.035$), fruit yield per plant ($r_g=0.030$, $r_p=0.008$) (Table 4).

4.3.18 Moisture percentage

Moisture percentage showed significantly negative association with individual fruit weight ($r_g=-0.543$, $r_p=-0.521$) and fruit yield per plant ($r_g=-0.440$, $r_p=-0.364$) (Table 4).

4.3.19 Individual fruit weight (g)

Individual fruit weight showed highly significant and positive correlation with fruit yield per plant ($r_g=0.875$, $r_p=0.728$) (Table 4). Akhter (2021) and Weber and Moorthy (2010) also found the evidence of positive and strong association between yield per plant and fruit weight. Megha *et al.* (2006) found that individual fruit weight had significant positive correlations with yield per plant. Arun *et al.* (2004) and Joshi *et al.* (2004) observed that in case of tomato yield per plant was positively and significantly correlated with average fruit weight. Matin *et al.* (2001) also found similar result for this trait in tomato. Kumar *et al.* (2004) and Manivannan *et al.* (2005) showed that yield per plant was positively and significantly correlated with individual fruit weight.

4.4 Path coefficient analysis

The path coefficient analysis technique was developed by Wright (1921) and demonstrated by Deway and Lu (1959) facilitates the portioning of correlation coefficients into direct and indirect contribution of various characters on yield. It is standardized partial regression coefficient analysis. As such, it measures the direct influence of one variable upon other. Such information would be of great value in enabling the breeder to specifically identify the important component traits of yield and utilize the genetic stock for improvement in a planned way. The direct and indirect effects of yield contributing characters on yield were worked out by using path analysis. Here yield per plant was considered as effect (dependent variable) and days of first flowering, days to 50% flowering, days to first fruiting, days to maturity, plant height (cm), number of branches per plant, number of clusters per plant, number of flowers per cluster, number of fruits per cluster, number of fruits per plant, fruit length (mm), fruit

diameter (mm), skin diameter (mm), No. of locules per fruit, Total soluble solids, pH, Relative water content, Moisture percentage, Individual fruit weight (g) were treated as independent variables. Path coefficient analysis was showed direct and indirect effects of different characters on yield of tomato in (Table 5).

4.4.1 Days to first flowering

Days to first flowering had negative direct effect (-0.086) on yield per plant (Table 5) which is contributed to result highly significant but negative genotypic correlation with yield per plant (-0.260). Matin *et al.* (2001) reported that days to first flowering had negative direct effect on yield per plant. It showed positive indirect effect on days to first fruiting (0.021), number of branches per plant (0.060), number of clusters per plant (0.171), number of flowers per cluster (0.059), number of fruits per cluster (0.376), fruit length (0.057), skin diameter (0.120), locule number (0.047), pH (0.017) and relative water content (0.338). Negative indirect effect was found on days to 50% flowering (-0.096), days to maturity (-0.098), plant height (-0.110), number of fruits per plant (-0.490), fruit diameter (-0.036), total soluble solids (-0.232), moisture percentage (-0.185) and individual fruit weight (-0.194). Bhuiyan (2014) also found negative indirect effect on days to 50% flowering, plant height and fruits per plant.

4.4.2 Days to 50% flowering

Days to 50% flowering had negative direct effect (-0.231) on yield per plant (Table 5) which is contributed to result highly significant but negative genotypic correlation with yield per plant (-0.505). Singh *et al.* (2006) showed that days to 50% flowering had high positive direct effect on yield which does not support the present findings. It showed positive indirect effect on days to first fruiting (0.090), number of branches per plant (0.132), number of clusters per plant (0.618), number of flowers per cluster (0.142), number of fruits per cluster (0.198), fruit length (0.153), fruit diameter (0.475), pH (.004) and relative water content (0.078). Negative indirect effect was found on days to first flowering (-0.036), days to maturity (-0.150), plant height (-0.313), number of fruits per

Table 5. Path coefficient analysis showing direct (bold) and indirect effects of different characters on yield of tomato

Traits	DFE	DFPF	DFFr	DM	PH	NBP	NCP	NFC	NfrC	NFrP	FL	FD	SD	LN	TSS	pH	RWC	MP	IFrW	YP
DFE	-0.086	-0.096	0.021	-0.098	-0.110	0.060	0.171	0.059	0.376	-0.490	0.057	-0.036	0.120	0.047	-0.232	0.017	0.338	-0.185	-0.194	-0.260**
DFPF	-0.036	-0.231	0.090	-0.150	-0.313	0.132	0.618	0.142	0.198	-0.554	0.153	0.475	-0.040	-0.062	-0.495	0.004	0.078	-0.126	-0.338	-0.505**
DFFr	-0.011	-0.123	0.169	-0.098	-0.250	0.018	0.560	0.005	0.330	-0.658	0.049	0.345	0.058	-0.134	-0.328	0.020	0.178	-0.194	-0.428	-0.493**
DM	-0.045	-0.185	0.089	-0.187	-0.266	0.153	0.897	0.015	0.285	-0.791	0.147	0.449	-0.005	-0.067	-0.377	0.004	0.111	-0.294	-0.468	-0.539**
PH	-0.015	-0.114	0.067	-0.079	-0.635	0.006	0.219	0.100	0.211	-0.276	0.120	0.757	-0.072	-0.139	-0.367	-0.037	0.135	-0.121	-0.509	-0.748**
NBP	-0.013	-0.077	0.008	-0.072	-0.010	0.395	0.104	-0.110	0.525	-0.393	0.108	0.229	-0.027	-0.084	-0.314	0.010	-0.291	-0.292	-0.477	-0.712**
NCP	-0.010	-0.099	0.066	-0.116	-0.096	0.028	1.443	-0.135	0.066	-0.901	0.147	0.554	-0.227	-0.101	-0.335	0.012	-0.030	-0.185	-0.465	-0.384**
NFC	0.010	0.067	-0.002	0.006	0.130	0.089	0.400	-0.488	0.121	-0.316	-0.117	-0.169	0.013	-0.068	0.342	0.068	0.334	-0.103	0.085	0.403**
NfrC	-0.035	-0.049	0.060	-0.058	-0.145	0.224	0.103	-0.064	0.926	-0.750	0.059	0.288	0.059	-0.122	-0.191	0.019	0.047	-0.260	-0.414	-0.304**
NFrP	-0.037	-0.112	0.097	-0.130	-0.153	0.136	1.138	-0.135	0.607	-1.144	0.156	0.589	-0.125	-0.146	-0.376	0.021	0.031	-0.296	-0.600	-0.478**
FL	0.022	0.156	-0.037	0.122	0.337	-0.188	-0.940	-0.252	-0.239	0.789	-0.226	-0.545	0.198	0.035	0.526	0.0004	0.101	0.219	0.490	0.567**
FD	-0.003	0.115	-0.061	0.088	0.502	-0.123	-0.836	-0.086	-0.279	0.704	-0.129	-0.957	0.177	0.206	0.481	0.025	-0.104	0.247	0.517	0.484**
SD	-0.023	0.021	0.022	0.002	0.103	-0.024	-0.742	-0.015	0.123	0.322	-0.102	-0.383	0.442	0.053	0.123	-0.014	0.063	0.053	0.198	0.222*
LN	-0.015	0.054	-0.085	0.047	0.332	-0.125	-0.550	0.126	-0.426	0.631	-0.029	-0.744	0.088	0.265	0.335	0.040	-0.134	0.156	0.442	0.407**
TSS	-0.024	-0.138	0.067	-0.085	-0.280	0.149	0.582	0.201	0.213	-0.518	0.143	0.555	-0.065	-0.107	-0.830	0.005	0.090	-0.182	-0.494	-0.719**
pH	0.011	0.007	-0.025	0.005	-0.172	-0.028	-0.129	0.244	-0.129	0.180	-0.0003	0.176	0.047	-0.078	0.032	-0.135	-0.103	0.046	-0.055	-0.107ns
RWC	-0.040	-0.025	0.041	-0.028	-0.117	-0.157	-0.060	-0.222	0.060	-0.049	-0.031	0.136	0.038	-0.048	-0.102	0.019	0.733	-0.144	0.027	0.030ns
MP	-0.029	-0.054	0.061	-0.102	-0.143	0.213	0.493	-0.093	0.445	-0.626	0.092	0.438	-0.043	-0.076	-0.279	0.011	0.195	-0.541	-0.402	-0.440**
IFrW	0.023	0.121	-0.098	0.119	0.437	-0.255	-0.908	-0.056	-0.519	0.929	-0.150	-0.669	0.118	0.159	0.554	0.010	0.027	0.294	0.739	0.875**

Residual effect **0.002** ** = Significant at 1%. * = Significant at 5%. ns = Non-significant.

Note: DFF=Days to first flowering, DFPF=Days to 50% flowering, DFFr=Days to first fruiting, DM=Days to maturity, PH=Plant height (cm), NBP=No. of branches per plant, NCP=No. of clusters per plant, NFC=No. of flowers per cluster, NFrC=No. of fruits per cluster, NFrP=No. of fruits per plant, FL=Fruit length (cm), FD=Fruit diameter (cm), SD=Skin diameter (mm), LN= Locule number, TSS=Total soluble solids, pH, RWC=Relative water content, MP=Moisture percentage, IFrW=Individual fruit weight (g), YP=Yield per plant (kg).

plant (-0.554), skin diameter (-0.040), locule number (-0.062), total soluble solids (-0.495), moisture percentage (-0.126) and individual fruit weight (-0.338).

4.4.3 Days to first fruiting

Days to first fruiting had positive direct effect (0.169) on yield per plant (Table 5) which is contributed to result highly significant but negative genotypic correlation with yield per plant (-0.493). It had positive indirect effect on number of branches per plant (0.018), number of clusters per plant (0.560), number of flowers per cluster (0.005), number of fruits per cluster (0.330), fruit length (0.049), fruit diameter (0.345), skin diameter (0.058), pH (0.020) and relative water content (0.178). Negative indirect effect was also found on days to first flowering (-0.011), days to 50% flowering (-0.123), days to maturity (-0.098), plant height (-0.250), number of fruits per plant (-0.658), locule number (-0.134), total soluble solids (-0.328), moisture percentage (-0.194) and individual fruit weight (-0.428).

4.4.4 Days to maturity

Days to maturity had negative direct effect (-0.187) on yield per plant (Table 5) which is contributed to result highly significant but negative genotypic correlation with yield per plant (-0.539). Singh *et al.*, (2005) reported that days to maturity had high negative direct effects on yield in tomato. It had positive indirect effect on days to first fruiting (0.089), number of branches per plant (0.153), number of clusters per plant (0.897), number of flowers per cluster (0.015), number of fruits per cluster (0.285), fruit length (0.147), fruit diameter (0.449), pH (0.004) and relative water content (0.111). Negative indirect effect was also found on days to first flowering (-0.045), days to 50% flowering (-0.185), plant height (-0.266), number of fruits per plant (-0.791), skin diameter (-0.005), locule number (-0.067), total soluble solids (-0.377), moisture percentage (-0.294) and individual fruit weight (-0.468).

4.4.5 Plant height

Plant height had negative direct effect (-0.635) on yield per plant (Table 5), which is contributed to result highly significant but negative genotypic correlation with yield per plant (-0.748). *Matin et al.* (2001) reported that plant height showed negative direct effect on yield per plant. It had positive indirect effect on days to first fruiting (0.067), number of branches per plant (0.006), number of clusters per plant (0.219), number of flowers per cluster (0.100), number of fruits per cluster (0.211), fruit length (0.120), fruit diameter (0.757) and relative water content (0.135). On the other hand, plant height showed negative indirect effect on yield per plant through days to first flowering (-0.015), days to 50% flowering (-0.114), days to maturity (-0.079), number of fruits per plant (-0.276), skin diameter (-0.072), locule number (-0.139), total soluble solids (-0.367), pH (-0.037), moisture percentage (-0.121) and individual fruit weight (-0.509).

4.4.6 Number of branches per plant

Number of branches per plant showed positive direct effect (0.395) on yield per plant and significant negative correlation (-0.712) at genotypic level (Table 5). *Akhter* (2021), *Padda et al.* (2007) and *Verma et al.* (2000) also observed that number of branches per plant exhibited positive direct effect on yield per plant. It had positive indirect effect on days to first fruiting (0.008), number of clusters per plant (0.104), number of fruits per cluster (0.525), fruit length (0.108), fruit diameter (0.229) and pH (0.010). Negative indirect effect was also found on days to first flowering (-0.013), days to 50% flowering (-0.077), days to maturity (-0.072), plant height (-0.010), number of flowers per cluster (-0.110), number of fruits per cluster (-0.393), skin diameter (-0.027), locule number (-0.084), total soluble solids (-0.314), relative water content (-0.291), moisture percentage (-0.292) and individual fruit weight (-0.477).

4.4.7 Number of clusters per plant

Number of clusters per plant showed positive direct effect (1.443) on yield per plant and significant negative correlation (-0.384) at genotypic level (Table 5). *Akhter* (2021) also

observed positive direct effects in her study. Singh *et al.* (2005) reported that number of clusters per plant had negative effects on yield per plant at genotypic level. It had positive indirect effect on days to first fruiting (0.066), number of branches per plant (0.028) and number of fruits per cluster (0.066), fruit length (0.147), fruit diameter (0.554) and pH (0.012). Negative indirect effect was also found on days to first flowering (-0.010), days to 50% flowering (-0.099), days to maturity (-0.116), plant height (-0.096), number of flowers per cluster (-0.135), number of fruits per plant (-0.901), skin diameter (-0.227), locule number (-0.101), total soluble solids (-0.335), relative water content (-0.030), moisture percentage (-0.185) and individual fruit weight (-0.465).

4.4.8 Number of flowers per cluster

Number of flowers per cluster showed negative direct effect (-0.488) on yield per plant. It had also highly significant positive correlation with yield per plant (0.403) at genotypic level (Table 5). Number of flowers per cluster had positive indirect effect on days to first flowering (0.010), days to 50% flowering (0.067), days to maturity (0.006), plant height (0.130), number of branches per plant (0.089), number of clusters per plant (0.400), number of fruits per cluster (0.121), skin diameter (0.013), total soluble solids (0.342), pH (0.068), relative water content (0.334) and individual fruit weight (0.085). Negative indirect effect was also found on days to first fruiting (-0.002), number of fruits per plant (-0.316), fruit length (-0.117), fruit diameter (-0.169), locule number (-0.068) and moisture percentage (-0.103).

4.4.9 Number of fruits per cluster

Number of fruits per cluster showed positive direct effect (0.926) on yield per plant. It had also highly significant negative correlation with yield per plant (-0.304) at genotypic level (Table 5). Bhuiyan (2014) and Mayavel *et al.* (2005) reported that number of fruits per cluster had negative direct effects on fruit yield. Number of fruits per cluster had positive indirect effects on days to first fruiting (0.060), number of branches per plant (0.224), number of clusters per plant (0.103), fruit length (0.059), fruit diameter (0.288), skin diameter (0.059), pH (0.019) and relative water content (0.147). Negative indirect effect was also found on days to first flowering (-0.035), days to 50% flowering (-0.049),

days to maturity (-0.058), plant height (-0.145), number of flowers per cluster (-0.064), number of fruits per plant (-0.750), locule number (-0.122), total soluble solids (-0.191), moisture percentage (-0.260) and individual fruit weight (-0.414).

4.4.10 Number fruits per plant

Number of fruits per plant showed negative direct effect (-1.144) on yield per plant. It had also highly significant negative correlation with yield per plant (-0.478) at genotypic level (Table 5). Number of fruits per plant had positive indirect effects on days to first fruiting (0.097), number of branches per plant (0.136), number of clusters per plant (1.138), number of fruits per cluster (0.607), fruit length (0.156), fruit diameter (0.589), pH (0.021) and relative water content (0.031). Negative indirect effect was also found on days to first flowering (-0.037), days to 50% flowering (-0.112), days to maturity (-0.130), plant height (-0.153), number of flowers per cluster (-0.135), skin diameter (-0.125), locule number (-0.146), total soluble solids (-0.376), moisture percentage (-0.296) and individual fruit weight (-0.600). Singh *et al.* (2006) and Kumar *et al.* (2003) observed fruits per plant had direct positive effects on fruit yield at the genotypic level that was not similar to the present findings.

4.4.11 Fruit length

Fruit length had negative direct effect (-0.226) on yield per plant. It had also significant positive correlation with yield per plant (0.567) at genotypic level (Table 5). Padda *et al.* (2007) and Singh *et al.* (2006) also revealed that fruit length exhibited positive effect on yield per plant at the genotypic level. This trait had also indirect positive effect on days to first flowering (0.022), days to 50% flowering (0.156), days to maturity (0.122), plant height (0.337), number of fruits per plant (0.789), skin diameter (0.198), locule number (0.035), total soluble solids (0.526), pH (0.0004), relative water content (0.101), moisture percentage (0.219) and individual fruit weight (0.490). Negative indirect effect was also found on days to first fruiting (-0.037), number of branches per plant (-0.188), number of clusters per plant (-0.940), number of flowers per cluster (-0.252), number of fruits per cluster (-0.239) and fruit diameter (-0.545).

4.4.12 Fruit diameter

Fruit diameter showed negative direct effect (-0.957) on yield per plant. It had also highly significant positive correlation with yield per plant (0.484) at genotypic level (Table 5). Padma *et al.* (2002) found that fruit diameter had high positive direct effect on fruit yield at the genotypic level. It had positive indirect effect on days to 50% flowering (0.115), days to maturity (0.088), plant height (0.502) and number of fruits per plant (0.704), skin diameter (0.177), locule number (0.206), total soluble solids (0.481), pH (0.025), moisture percentage (0.247) and individual fruit weight (0.517). Negative indirect effect was also found on days to first flowering (-0.003), days to first fruiting (-0.061), number of branches per plant (-0.123), number of clusters per plant (-0.836), number of flowers per cluster (-0.086), number of fruits per cluster (-0.279), fruit length (-0.129) and relative water content (-0.104).

4.4.13 Skin diameter

Skin diameter showed positive direct effect (0.442) on yield per plant. It had also significant positive correlation with yield per plant (0.222) at genotypic level (Table 5). It had positive indirect effect on days to 50% flowering (0.021), days to first fruiting (0.022), days to maturity (0.002), plant height (0.103), number of fruits per cluster (0.123), number of fruits per plant (0.322), locule number (0.053), total soluble solids (0.123), relative water content (0.063), moisture percentage (0.053) and individual fruit weight (0.198). Negative indirect effect was also found on days to first flowering (-0.023), number of branches per plant (-0.024), number of clusters per plant (-0.742), number of flowers per plant (-0.015) fruit length (-0.102), fruit diameter (-0.383) and pH (-0.014).

4.4.14 Locule number

Locule number showed positive direct effect (0.265) on yield per plant. It had also highly significant positive correlation with yield per plant (0.407) at genotypic level (Table 5). It had positive indirect effect on days to 50% flowering (0.054), days to maturity (0.047), plant height (0.332), number of flowers per cluster (0.126), number of fruits per plant

(0.631), skin diameter (0.088), total soluble solids (0.335), pH (0.040), moisture percentage (0.156) and individual fruit weight (0.442). Negative indirect effect was also found on days to first flowering (-0.015), days to first fruiting (-0.085), number of branches per plant (-0.125), number of clusters per plant (-0.550), number of fruits per cluster (-0.426) fruit length (-0.029), fruit diameter (-0.744) and relative water content (-0.134).

4.4.15 Total soluble solids

Total soluble solids showed negative direct effect (-0.830) on yield per plant. It had also significant negative correlation with yield per plant (-0.719) at genotypic level (Table 5). It had positive indirect effect on days to first fruiting (0.067), number of branches per plant (0.149), number of clusters per plant (0.582), number of flowers per cluster (0.201), number of fruits per cluster (0.213), fruit length (0.143), fruit diameter (0.555), pH (0.005) and relative water content (0.090). Negative indirect effect was also found on days to first flowering (-0.024), days to 50% flowering (-0.138), days to maturity (-0.085), plant height (-0.280), number of fruits per plant (-0.518), skin diameter (-0.065) and locule number (-0.107), moisture percentage (-0.182) and individual fruit weight (-0.494).

4.4.16 pH

pH showed negative direct effect (-0.135) on yield per plant. It had also non-significant negative correlation with yield per plant (-0.107) at genotypic level (Table 5). It had positive indirect effect on days to first flowering (0.011), days to 50% flowering (0.007), days to maturity (0.005), number of flowers per cluster (0.244), number of fruits per plant (0.180), fruit diameter (0.176), skin diameter (0.047), total soluble solids (0.032) and moisture percentage (0.046). Negative indirect effect was also found on days to first fruiting (-0.025), plant height (-0.172), number of branches per plant (-0.028), number of clusters per plant (-0.129), number of fruits per cluster (-0.129), fruit length (-0.0003), locule number (-0.078), relative water content (-0.103) and individual fruit weight (-0.055).

4.4.17 Relative water content

Relative water content showed positive direct effect (0.733) on yield per plant. It had also non-significant positive correlation with yield per plant (0.030) at genotypic level (Table 5). It had positive indirect effect on days to first fruiting (0.041), number of fruits per cluster (0.060), fruit diameter (0.136), skin diameter (0.038), pH (0.019) and individual fruit weight (0.027). Negative indirect effect was also found on days to first flowering (-0.040), days to 50% flowering (-0.025), days to maturity (-0.028), plant height (-0.117), number of branches per plant (-0.157), number of clusters per plant (-0.060), number of flowers per cluster (-0.222), number of fruits per plant (-0.049), fruit length (-0.031), locule number (-0.048), total soluble solids (-0.102) and moisture percentage (-0.144).

4.4.18 Moisture percentage

Moisture percentage showed negative direct effect (-0.541) on yield per plant. It had also significant negative correlation with yield per plant (-0.440) at genotypic level (Table 5). It had positive indirect effect on days to first fruiting (0.061), number of branches per plant (0.213), number of clusters per plant (0.493), number of fruits per cluster (0.445), fruit length (0.092), fruit diameter (0.438), pH (0.011) and relative water content (0.195). Negative indirect effect was also found on days to first flowering (-0.029), days to 50% flowering (-0.054), days to maturity (-0.102), plant height (-0.143), number of flowers per cluster (-0.093), number of fruits per plant (-0.626), skin diameter (-0.043), locule number (-0.076), total soluble solids (-0.279) and individual fruit weight (-0.402).

4.4.19 Individual fruit weight

Path analysis revealed that individual fruit weight had direct positive effect (0.739) on yield per plant and highly significant positive correlation with yield per plant (0.875) at genotypic level (Table 5). This trait had also indirect positive effect on days to first flowering (0.023), days to 50% flowering (0.121), days to maturity (0.119), plant height (0.437), number of fruits per plant (0.929), skin diameter (0.118), locule number (0.159), total soluble solids (0.554), pH (0.010), relative water content (0.027) and moisture percentage (0.294). Negative indirect effect was also found on days to first fruiting (-0.098), number of branches per plant (-0.255), number of clusters per plant (-0.908),

number of flowers per cluster (-0.056), number of fruits per cluster (-0.519), fruit length (-0.150) and fruit diameter (-0.669). Akhter (2021), Rani *et al.* (2010), Singh *et al.* (2006); Manivannan *et al.* (2005) and Padma *et al.* (2002) also reported positive direct effects on fruit yield.

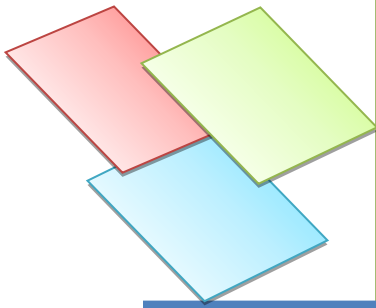

***SUMMARY AND
CONCLUSION***



CHAPTER V

SUMMARY AND CONCLUSION

This study was conducted at the research field of the Sher-e-Bangla Agricultural University, Dhaka, during the period from November 2019 to March 2020 with 39 genotypes of tomato (*Solanum lycopersicum* L.). The data pertaining to twenty characters have been presented and statistically analyzed with the possible interpretations. The experiment was laid out in Randomized Complete Block Design with three replications. Variability, mean performance, correlation and path analysis on different yield and yield contributing characters such as days to first flowering, days to 50% flowering, days to first fruiting, days to maturity, plant height (cm), number of branches per plant, number of clusters per plant, number of flowers per cluster, number of fruits per cluster, number of fruits per plant, fruit length (cm), fruit diameter (cm), skin diameter (mm), locule number, total soluble solids, pH, relative water content, moisture percentage, individual fruit weight (g) and yield per plant (kg) of tomato genotypes were estimated. The mean sum of squares (MS) revealed highly significant difference among the genotypes for all the characters under study, suggesting presence of substantial amount of variability for all the characters in 39 genotypes.

The longer period of days to first flowering was found in $G_3 \times G_1$ (44.33 DAT) and the earlier period of days to first flowering was found in $G_7 \times G_5$ (24.33 DAT). The highest days to 50% flowering was found in $G_6 \times G_3$ (82.00 DAT) and the lowest days to 50% flowering was found in $G_2 \times G_7$, $G_3 \times G_2$, $G_6 \times G_7$, $G_7 \times G_3$, $G_7 \times G_6$ (72.00 DAT). The longer period of days to first fruiting was found in $G_7 \times G_1$ (72.00 DAT) and the earlier period of days to first fruiting was found in $G_6 \times G_7$, $G_7 \times G_6$ (49.33 DAT). The longer period of days to maturity was found in $G_4 \times G_1$ (109 DAT) and the earlier period of days to maturity was found in $G_2 \times G_5$ (89.67 DAT). The highest plant height was found in $G_8 \times G_1$ (99.56 cm) and the lowest plant height was found in $G_4 \times G_5$ (72.00 cm). The highest number of branches per plant was found in $G_6 \times G_3$, $G_7 \times G_1$ (12.00) and the lowest number of branches per plant was found in $G_4 \times G_5$ (7.67). The highest number of clusters per plant was found in $G_3 \times G_1$ (30.00) and the lowest number of clusters per plant was found in $G_4 \times G_8$ (15.33). The highest number of flowers per cluster was found

in $G_2 \times G_7$, $G_4 \times G_5$ (9.33) and the lowest number of flowers per cluster was found in $G_1 \times G_7$, $G_2 \times G_4$ (6.00). The highest number of fruits per cluster was found in $G_6 \times G_5$ (7.33) and the lowest number of fruits per cluster was found in $G_2 \times G_5$ (4.33).

The highest number of fruits per plant was found in $G_3 \times G_1$ (180) and the lowest number of fruits per plant was found in $G_1 \times G_4$ (74.33). The highest fruit length was found in $G_2 \times G_7$ (36.00 cm) and the lowest fruit length was found in $G_6 \times G_3$ (7.67 cm). The highest fruit diameter was found in $G_1 \times G_4$ (48.00 cm) and the lowest fruit diameter was found in $G_1 \times G_6$ (13.33 cm). The highest skin diameter was found in $G_1 \times G_3$ (6.17 mm) and the lowest skin diameter was found in $G_7 \times G_6$ (2.9 mm). The highest number of locule was found in $G_1 \times G_4$ (8.67) and the lowest number of locule was found in $G_1 \times G_7$, $G_2 \times G_5$, $G_3 \times G_1$, $G_5 \times G_6$, $G_5 \times G_8$, $G_7 \times G_3$ (2.00). The highest total soluble solids value was found in $G_1 \times G_5$ (6.37) and the lowest total soluble solids value was found in $G_1 \times G_3$, $G_1 \times G_4$, $G_2 \times G_1$, $G_2 \times G_5$, $G_3 \times G_2$, $G_4 \times G_5$, $G_6 \times G_7$, $G_7 \times G_3$ (1.00). The highest pH value was found in $G_1 \times G_7$ (6.55) and the lowest pH value was found in $G_1 \times G_4$, $G_7 \times G_1$, $G_7 \times G_6$ (3.65). The highest amount of relative water content was found in $G_6 \times G_2$ (88.79) and the lowest amount of relative water content was found in $G_2 \times G_3$ (52.31). The highest moisture percentage value was found in $G_1 \times G_5$, $G_1 \times G_6$, $G_4 \times G_3$, $G_4 \times G_6$, $G_4 \times G_7$, $G_4 \times G_8$, $G_5 \times G_6$, $G_6 \times G_3$, $G_7 \times G_8$ (99.98) and the lowest moisture percentage value was found in $G_1 \times G_4$, $G_6 \times G_7$ (94.62). The highest individual fruit weight was found in $G_1 \times G_4$, $G_2 \times G_1$ (61 g) and the lowest individual fruit weight was found in $G_4 \times G_2$ (13.53 g). The highest fruit yield per plant was found in $G_2 \times G_1$ (4.62 kg) and the lowest fruit yield per plant was found in $G_5 \times G_3$ (1.54 kg).

The phenotypic variance (σ^2_p) appeared to be higher than the genotypic variance (σ^2_g) suggested considerable influence of environment on the expression of genes controlling these traits. The genotypic co-efficient of variation (GCV) was less than the phenotypic co-efficient of variation (PCV) for all the characters. In this study, high phenotypic co-efficient of variation (PCV) and genotypic coefficient of variation (GCV) were observed for fruit length (cm), fruit diameter (cm), locule number, total soluble solids, individual fruit weight and fruit yield per plant, indicating the higher magnitude of variability for these traits and consequently more scope for their improvement through selection.

Moderate PCV and GCV were estimated for number of clusters per plant, number of fruits per cluster, skin diameter (mm), pH and relative water content, implying equal importance of additive and non-additive gene action.

Low GCV and PCV estimation were recorded for days to 50% flowering, days to maturity and moisture percentage which indicated presence of low variability among the genotypes. The genotypic co-efficient of variation and the phenotypic co-efficient of variation was more or less similar to each other for days to 50% flowering, days to maturity, fruit length, fruit diameter, skin diameter, locule number, total soluble solids, pH, relative water content, moisture percentage, individual fruit weight and fruit yield per plant, indicating minor environmental influence and high degree of genetic variability present on the expression of these characters. Thus a greater scope for effective selection exists based upon phenotypic expression of these characters for the improvement of this crop. The wider PCV and GCV values were observed for days to first flowering, days to first fruiting, plant height, number of branches per plant, number of flowers per cluster and number of fruits per plant, indicating dominant role played by the environment in the expression of these traits and were not desirable for the improvement of this crop.

Days to 50% flowering, days to maturity, fruit length (cm), fruit diameter (cm), locule number, total soluble solids, pH, relative water content, moisture percentage, individual fruit weight (g) and fruit yield per plant (kg) showed high heritability. High heritability indicates that the environmental influence is minimal on those characters. This result suggested selection could be fairly easy and improvement is possible using selection breeding for these traits improvement. Number of fruits per cluster and skin diameter (mm) showed moderate heritability. It indicates that the selection should be delayed to more advance generations for these traits. Days to first flowering, days to first fruiting, plant height, number of branches per plant, number of clusters per plant, number of flowers per cluster, number of fruits per plant showed low heritability. These traits might be controlled by many genes. The progress in selection for this character in tomato is generally slow. Fruit length (cm), fruit diameter (cm), skin diameter (mm), locule number, total soluble solids, pH, relative water content, individual fruit weight (g) and fruit yield per plant (kg) had high genetic advance in percent of mean in the current

study. In this study, high heritability coupled with high genetic advance in percentage of mean for fruit length (cm), fruit diameter (cm), skin diameter (mm), locule number, total soluble solids, pH, relative water content, individual fruit weight (g) and fruit yield per plant (kg) were obtained suggesting that these traits were highly heritable and there is a wide scope for improvement through selection of these traits. Most likely the heritability of these traits is due to additive gene effects and selection may be effective in early generations for these traits.

Correlation coefficient revealed that yield per plant had positively significant association with number of flowers per cluster, fruit length, fruit diameter, locule number, individual fruit weight for both genotypic and phenotypic level and skin diameter only for genotypic level, indicating that a possible increase in these traits tends to increase in fruit yield per plant. It had also negatively significant association with days to first flowering, days to 50% flowering, days to first fruiting, days to maturity, plant height, number of branches per plant, number of clusters per plant, number of fruits per cluster, number of fruits per plant, total soluble solids and moisture percentage for both genotypic and phenotypic level indicating that a possible decrease in these traits tends to increase in fruit yield per plant.

Path analysis expressed a positive direct effect on yield per plant for the characters such as days to first fruiting, number of branches per plant, number of clusters per plant, number of fruits per cluster, skin diameter, locule number, relative water content, moisture percentage and individual fruit weight. Number of flowers per cluster, fruit length, fruit diameter, skin diameter, locule number and individual fruit weight had also significant positive correlation with yield per plant at genotypic level, indicating that these were the main contributors to yield per plant and there is a great extent of possibility of improving fruit yield through selection based on these characters.

Conclusion

Based on the findings of the study, conclusion was plotted and their logical interpretations in the light of the other relevant factors are prepared below:

1. In respect of field performance, $G_1 \times G_3$, $G_1 \times G_4$, $G_1 \times G_5$, $G_1 \times G_6$, $G_1 \times G_7$, $G_2 \times G_1$, $G_2 \times G_5$, $G_2 \times G_7$, $G_3 \times G_1$, $G_3 \times G_2$, $G_4 \times G_2$, $G_4 \times G_3$, $G_4 \times G_5$, $G_4 \times G_6$, $G_4 \times G_7$, $G_4 \times G_8$, $G_5 \times G_6$, $G_6 \times G_2$, $G_6 \times G_3$, $G_6 \times G_5$, $G_6 \times G_7$, $G_7 \times G_1$, $G_7 \times G_3$, $G_7 \times G_5$, $G_7 \times G_6$, $G_7 \times G_8$, $G_8 \times G_1$ genotypes are promising. Among the genotypes, the highest fruit diameter, highest locule number, lowest total soluble solids, lowest pH, lowest moisture percentage, highest individual fruit weight and highest fruit yield per plant were found in $G_1 \times G_4$ genotype. Early flowering was found in $G_7 \times G_5$ genotype but early fruiting was found in $G_6 \times G_7$ and $G_7 \times G_6$ genotypes. In case of early maturity, $G_2 \times G_5$ genotype was dominant.

2. High phenotypic coefficient of variation (PCV) and genotypic coefficient of variation (GCV) were observed for fruit length (cm), fruit diameter (cm), locule number, total soluble solids, individual fruit weight and fruit yield per plant. High heritability coupled with high genetic advance in percentage of mean were obtained for fruit length (cm), fruit diameter (cm), skin diameter (mm), locule number, total soluble solids, pH, relative water content, individual fruit weight and fruit yield per plant.

3. Correlation coefficient revealed that yield per plant had positively significant association with number of flowers per cluster, fruit length, fruit diameter, locule number, individual fruit weight and negatively significant association with days to first flowering, days to 50% flowering, days to first fruiting, days to maturity, plant height, number of branches per plant, number of clusters per plant, number of fruits per cluster, number of fruits per plant, total soluble solids, moisture percentage for both genotypic and phenotypic level.

4. Path analysis revealed that days to first fruiting, number of branches per plant, number of clusters per plant, number of fruits per cluster, skin diameter, locule number, relative water content, moisture percentage and individual fruit weight showed positive direct effect on yield. Number of flowers per cluster, fruit length, fruit diameter, skin diameter,

locule number and individual fruit weight had also significant positive correlation with yield per plant at genotypic level.

Therefore, for the selection of tomato genotypes the above parameters should have to be taken with due consideration.

Recommendations

Based on findings and conclusions of the study, recommendations are presented below:

1. $G_1 \times G_4$ genotype can be used as high yielding and for more souring variety.
2. The reciprocal genotypes $G_6 \times G_7$ and $G_7 \times G_6$ can be consumed as green fruits because it starts fruiting in 49.33 days after transplanting.
3. $G_2 \times G_5$ genotype can be used as short durated ripen fruit variety because of its early maturity about 89.67 days after transplanting. The following aspects would be considered in future for the selection.

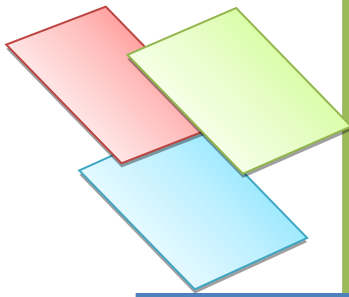

REFERENCES



CHAPTER VI

REFERENCES

- Aditya, P. Munar and A.R. Phir. (1995). Studied on genetic variability in tomato. *Progr. Hort.* **32**(2): 172-182.
- Agong, S.G., Schittenhelm, S. and Friedt, W. (2001). Genotypic variation of Kenyan tomato (*Lycopersicon esculentum* L.) germplasm. *J. Food Technol. African.* **6**(1): 13-17.
- Ahmad, M., Gul, Z. and Khan, Z.U. (2015). Study of heterosis in different cross combinations of tomato for yield and yield components. *Intl. J. Biol.* **7**(2): 12-18.
- Ahmed, S.U. (1987). Variability and Correlation studies in tomato. *Bangladesh J. Agric.* **12**(1): 1-4.
- Akhter, M. (2021). "Genetic variability, correlation coefficient, path coefficient and principal component analysis in tomato (*Solanum lycopersicum* L.) genotypes." *Plant cell biotechnol. Mol. Biol.* p. 46-59.
- Alam, K.S., Ishrat, E., Zaman, M.Y. and Habib, M.A. (2012). Comparative karyotype and PAPD analysis for characterizing three varieties of (*Solanum lycopersicum* L.). *Bangladesh J. Bot.* **41**(2): 149-154.
- Anandgowda, N. (1997). Variability and gene action-studies for characteristics related to processing in tomato (*Solanum lycopersicum* L.). *M.Sc. Thesis. Uni. Agric. Sci. Dharwad* (India).
- Anderson, T.W., and Goodman, L.A. (1957). Statistical inference about Markov chains. *Annal. Mathematical Stat.* p. 89-110
- Anitha, P., Sharma, R.R., Tiwari, R.N. and Surja, A.K. (2007). Correlation and path analysis for some horticultural traits in tomato. *Indian J. Hort.* **64**(1): 90-93.
- Anonymous, (2004). FAO irrigation and drainage paper. Food and Agricultural Organization of the United Nations, Rome, Italy, **3**: 80-82.
- Anonymous, (2010). FAO Static Division, Rome, Italy. www.faostat.fao.org.
- Anonymous, 1988. Production Year Book. Food and Agriculture Organization of the United Nations, Rome, Italy. **42**: 190-193.
- Anonymous, 2014. Year book of agriculture statistics. Bangladesh Bureau of Statistics. Ministry of planning's. Govt. peoples republic of Bangladesh, Dhaka.

- Anonymous. (2015). WWF and IUCN, Centres of Plant Diversity: **3**, The Americas, IUCN Publications Unit, Cambridge, England.
- Anonymous. (2016). World Cancer Research Fund / American Institute for Cancer Research. Food, Nutrition, Physical Activity, and the Prevention of Cancer: a Global Perspective.
- Anupam, B., Jain, B.P. and Verma, A.K. (2002). Genetic variability heritability and genetic advance in tomato (*Solanum lycopersicum* L.). *J. Res. Birsa Agric. Uni.* **14**(2): 249-252.
- Ara, A.R., Narayan, N. and Khan, S.H. (2009). Genetic variability and selection parameters for yield and quality attributes in tomato. *Indian J. Hort.* **66**: 73-78.
- Aradhana, J.C. and Singh, J.P. (2003). Studied on genetic variability in tomato. *Progr. Hort.* **35**(2): 179-182.
- Arun, J., Kohil, U.K. and Joshi, A. (2003). Genetic divergence for quantitative and qualitative traits in tomato (*Lycopersicon esculentum* M.). *Indian J. Agric. Sci.* **73**(2): 110-113.
- Bai, N.R. and Devi, D.S. (1991). Study on genetic parameters in tomato hybrids. *Orissa J. Agric. Res.* **4**: 27-29.
- Bai, Y. and Lindhot, P. (2007). Domestication and Breeding of Tomatoes: What Have We Gained and What Can We Gain in the Future. *Annals Bot.* **100**(5): 1085-1094.
- Bangaru, C., Muthukrishnan, C.R. and Irulappan. I. (1983). Genetic variation in F₂ generation of tomato. *Madras Hort. J.* **70**: 349-350.
- BARI, (2010). Bangladesh Agricultural Research Institute, Joydevpur, Gazipur-1701.
- Barone, A., Chiusano, M.L., Ercolano, M.R., Giuliano. G., Grandillo, S. and Frusciante, L. (2008). Structural and functional genomics of tomato. *Intl. Plant Genomics*, Article ID 820274. 12p.
- Barrs, H.D. and Weatherley, P.E. (1962). A re-examination of the relative turgidity technique for estimating water deficits in leaves. *Australian J. Biol. Sci.* **15**: 413-428.
- BBS (2019). Bangladesh Bureau of Statistics, Statistics and Informatics Division, Ministry of Planning, Government of the People's Republic of Bangladesh. <http://www.bbs.gov.bd>

- Bhuiyan, T.T.A. (2014). Genetic diversity analysis using yield contributing and nutritional traits of tomato (*Solanum lycopersicum* L.). MS thesis, Shere-e-bangla Agricultural University, Dhaka, Bangladesh.
- Bhuiyan, T.T.A., Rahman, M.M., Islam, M.R., Laylin, M.M.A. and Zeba, N. (2016). Estimation of genetic variability, heritability and genetic advance in agromorphogenic and nutritional traits of tomato (*Solanum lycopersicum* L.) genotypes. *J. Expt. Biosci.* **7**(1): 65-72.
- Bhusana, H.O., Kulkarni, R.S., Basavarajaiah, L., Helaswamy, B.H. and Halesh, G.K. (2001). Correlation and path analysis for fruit quality traits on fruit yield in tomato (*Lycopersicon esculentum* Mill.). *Crop Res. Sci.* **22**(1): 107-109.
- Bhutani, R.D. and Kalloo, G. (1989). Correlation and path coefficient analysis of some quality traits in tomato (*Lycopersicon esculentum* Mill.). *Haryana J. Hort. Sci.* **18**: 130-135.
- Brar, G.S., Singh, S., Chima, D.S. and Dhariwal, M.S. (2000). Studies on variability, heritability, genetic advance for yield and components characters in tomato (*Lycopersicon esculentum* Mill.). *J. Res. Punjab Agric. Univ.* **37**(3-4): 190-193.
- Buckseth, T., Sharma, K.M. and Thakur, K.S. (2012). Genetic diversity and path analysis in tomato (*Solanum lycopersicum* L.). *Veg. Sci.* **39**(2): 221-223.
- Burton, G.W. (1952). Quantitative interaction in grasses. *Indian Proc. Intl. Grassland Congr.* **1**: 277-283.
- Capanoglu, E., Beekwilder, J., Boyacioglu, D., De Vos, R. C. and Hall, R. D. (2010). The effect of industrial food processing on potentially health-beneficial tomato antioxidants, Critical reviews in food science and nutrition. **50**: 919-930.
- Cheema, D.S., Kumar, D. and Kaur, R. (2003). Diallel analysis for combining ability involving heat tolerant lines of tomato (*Lycopersicon esculentum* Mill.). *Crop Impro.* **30**(1): 39-44.
- Chen, X., Yang, D., Yang, Z., Li.Y.Y. and Zhang, H. (2009). The genetic analysis of quality of fruit of 7 tomato breeding lines. *J. Yunnan Agril. Univ.* **19**(5): 518-523.
- Chishti, S.A.S., Khan, A.A., Sadia, B. and Khan, I.A. (2008). Analysis of combining ability for yield, yield components and quality characters in tomato (*Lycopersicon esculentum* Mill.). *J. Agric. Res.* **46**(4): 325-332.

- Clarke, R.T. (1973). "A review of some mathematical models used in hydrology, with observations on their calibration and use." *J. Hydrol.* **19**: 1-20.
- Comstock, R.E. and Robinson, H. F. (1952). Genetic Parameters their estimation and significance. *Proc. 6th Intl. Grassland Cong.***1**: 128-291.
- Dennison, W.M. (1955). Reticulum-cell sarcoma in infancy. *Arch. disease childhood.* **30**(153): 472.
- Deshmukh, S.N., Basu, M.S. and Reddy P.S. (1986). "Genetic variability, character association and path coefficients of quantitative traits in Virginia bunch varieties of groundnut." *Indian J. Agric. Sci.* **41**(2): 245-547.
- Dev, H., Rattan, R.S., and Thakur, M.C. (1994). Heterosis in tomato. *Hort. J.* **7**(2): 125-132.
- Dewey, D.R. and Lu, K.N. (1959). A correlation and path coefficient analysis of components of crested wheat grass seed production. *Agron. J.* **51**: 515-518.
- Dhaliwal, M., Singh, S. and Cheema, D. (2013). Line x tester analysis for yield and processing attributes in tomato. *J. Res.* **40**: 49-53.
- Dhaliwal, M.S., Singh, S. and Cheema, D.S. (2002). Estimating combining ability effects of the genetic male sterile lines of tomato for their use in hybrid breeding. *J. Genet. Breed.* **54**(3): 199-205.
- Dhankar, S.K., Dhankar, B.S. and Sharma, N.K. (2001). Correlation and path analysis in tomato under normal and high temperature conditions. *Haryana J. Hort. Sci.* **30**(1-2): 89-92.
- Dhankhar, S.K. and Dhankar, S.S. (2006). Variability, heritability, correlation and path coefficient studies in tomato. *Haryana J. Hort. Sci.* **35**(1-2): 179-181.
- Domini, M.R. and Maya, C. (1997). Correlation and path coefficient estimates of different tomato seedlings stage. *Cult. Trop.* **18**(3): 63-65.
- Dufer, J.T. (2013). Evaluation of agronomic performance and lycopene variation in Tomato (*Lycopersicon esculantum* M.) genotypes in Mizan, southwestern Ethiopia. *World App. Sci. J.* **27**(11): 1450-1454.
- FAO, (2019). Food and Agriculture Organization of the United Nations, Rome, Italy. <http://www.fao.org/faostat/en/#data>
- FAOSTAT, (2019). Statistical data bases. Food and Agricultural Organization (FAO) of United Nations, Rome.

- Farzaneh, A., Nemati, H., Arouiee, H., Kakhki, A.M. (2013). Genetic analysis of traits associated with yield and earliness in nine tomato (*Lycopersicon esculentum* Mill.) lines using diallel crossing method. *J. Seed Plant Impro.* **29**(4): 693-710.
- Filippone, P.T. (2014). Tomato History - The history of tomatoes as food. Once considered poisonous. The tomato is now a favorite food. [Home Cooking Expert. http://homecooking.about.com/od/foodhistory/a/tomatohistory.htm](http://homecooking.about.com/od/foodhistory/a/tomatohistory.htm).
- Gentilcore, D. (2010). A history of the tomato in Italy Pomodoro. New York, NY: Columbia University Press, ISBN 023115206X.
- Ghosh, K.P., Islam, A.K.M.A., Mian, M.A.K., Hossain, M.M. (2010). Variability and character association in F₂ segregating population of different commercial hybrids of tomato (*Solanum lycopersicum* L.). *J. Appl. Sci. Environ. Manage.* **14**(2): 91-95.
- Ghosh, P.K., Syamal, M.M., Rai, N. and Joshi, A.K. (1995). Improvement of hybrid tomatoes. *Adv. Plant Sci.* **2**(1): 207-213.
- Golani, I.J., Mehta, D.R., Purohit, V.L., Pandya, H.M. and Kanzariya, M.V. (2007). Genetic variability, correlation and path coefficient studies in tomato. *Indian J. Agril.Res.* **41**(2): 146-149.
- Hannan, M.M., Ahmed, M.B., Razvy, M.A., Karim, R., Khatum, M., Hayder, A., Hussain, M. and Roy, U.K. (2007). Heterosis and correlation of yield and yield components in tomato. *American-Eurasian J. Sci. Res.* **2**(2): 146-150.
- Hanson, C.M., Robinsen, R.R. and Comstock, R.R. (2002). Biometrical studies on yield in segregating population of Korean. *Lespedeza. Agron. J.* **48**: 268-272.
- Harer, P.N., Lad, D.B. and Bhor, T.J. (2002). Correlation and path analysis studies in tomato. *J. Maharashtra Agric. Univ.* **27**(3): 302-303.
- Harvey, R.B. (1920). The relation between the total acidity, the concentration of the hydrogen ion, and the taste of acid solutions. *J. American Chemic. Soci.* **42**(4): 712-714.
- Heisar, C.J. (1969). Love apples. In Nightshades: The paradoxical plants. *Freemann, SanFrancisco, USA.* p. 53-105.
- Hernandez, L.E., Lobato, O.R., Garcia, Z.J.J., Lopez, D. and Hernandez, B.A. (2013). Agronomic performance of F₂ populations from tomato hybrids (*Solanum lycopersicum* L.). *Res. Fit. Mexicana.* **36**(3): 209-215.

- Hossain, A.K.M. and Ahmed, K.U. (1973). A comparative study on the performance of different varieties of tomato. Varietal responses of different spacing in respect of yield and other characterization of tomato varieties. *Bangladesh Hort.* **1**(1): 39-45.
- Hossain, M.M., Khalequzzaman, K.M., Amzad Hossain, M., Mollah, M.R.A. and Siddique, M.A. (2004). Influence of planting time on the extension of picking period of four tomato varieties. *J. Biol. Sci.* **4**: 616-619.
- Islam, M. Rafiqul. (2012). Characterization and diversity analysis of tomato (*Solanum lycopersicum* L.). Department of genetics and plant breeding, Sher-e-Bangla Agricultural University, Dhaka, Bangladesh.
- Islam, M.S. and Khan, S. (1991). Variability and character association in tomato (*Lycopersicon esculentum* Mill.). *Bangladesh. J. Plant Breed. Genet.* **4**(1-2): 49-53.
- Jenkins, J.A. (1948). The origin of cultivated tomato. *Econ. Botany.* **2**: 379.
- Johnson, H.W., Robinson, H.F. and Comstock, R.E. (1955). Estimation of genetic and environmental variability in soybean. *Agron. J.* **47**: 477-483.
- Joshi, A., Vikram, A. and Thakur, M.C. (2004). Studies on genetic variability, correlation and path analysis for yield and physico-chemical traits in tomato (*Solanum lycopersicum* L.). *Progr. Hort.* **36**(1): 51-58.
- Khapte, P.S. and Jansirani, P. (2014). Genetic variability and performance studies of tomato (*Solanum lycopersicum* L.) genotypes for fruit quality and yield. *Trends. Biosci.* **7**(12): 1246-1248.
- Korla, B.N., Thakur, B.S. and Joshi, A.K. (1998). Variability studies in beans. *Haryana J. Hort. Sci.* **27**: 43-48.
- Kumar, M. and Dudi, B.S. (2011). Study of correlation for yield and quality characters in tomato (*Lycopersicon esculentum* Mill.). *Electro. J. Plant Breed.* **2**(3): 453-460.
- Kumar, P. and Tewari, R.N. (1999). Studies on genetic variability for processing characters in tomato. *Indian. J. Hort.* **56**(4): 332-336.
- Kumar, R., Kumar, N., Singh, J. and Rai, G.K. (2006). Studies on yield and quality traits in tomato. *Veg. Sci.* **33**(2): 126-132.

- Kumar, S., Singh, T., Singh, B. and Singh, J.P. (2004). Studies on correlation coefficient and path analysis among the different characters including fruit yield of tomato (*Lycopersicon esculentum* Mill.). *Plant Arch.* **4**(1): 191-193.
- Kumar, V., Nandan, R., Srivastava, K., Sharma, S.K., Kumar, R. and Kuma, A. (2013). Genetic parameters and correlation study for yield and quality traits in tomato (*Solanum lycopersicum* L.). *Plant Arch.* **13**(1): 463-467.
- Kumar, V.R.A., Thakur, M.C. and Hedau, N.K. (2003). Correlation and path coefficient analysis in tomato (*Solanwn Lycopersicun* L.). *Annl. Agric. Res.* **24**(1): 170-177.
- Kumari, N., Srivastava, J.P., Shekhavat, A.K.S., Yadav, J.R. and Singh, B. (2007). Genetic variability and heritability of various traits in tomato (*Lycopersicon esculentum* Mill.). *Progr. Agric.* **7**(1-2): 80-83.
- Lush, J.L. (1943). Heritability of qualitative characters in farm animals. *Proc. 8th Cong. Genet. and Herid. Suppl.* 356-375.
- Mahalanobis, P.C. (2001). On the generalized distance in statistic. *Proc. Nat. acad. Sci.* **2**: 79-85.
- Mahapatra, A.S., Singh, A.K., Vani, V.M., Mishra, R., Kumar, H. and Rajkumar, B.V. (2013). Inter-relationship for various components and path coefficient analysis in tomato (*Lycopersicon esculentum* Mill.). *Intl. J. Cur. Microbiol. Appl. Sci.* **2**(9): 147-152.
- Mahesha, D.K., Apte, Y.B. and Jadhav, B.B. (2006). Studies on genetic divergence in tomato (*Solanum lycopersicum* L.). *Crop Res.* **32**(2): 401-402.
- Manivannan, K., Natarajan, J. and Irulappan, I. (2005). Correlation studies in tomato. *South Indian Hort.* **34**: 70-73.
- Mariane, F., Ravishankar, H. and Dessalegne, L. (2003). Study on variability in tomato gerrnplasm under conditions of Central Ethiopia. *Veg. Crops Res. Bull.* **58**: 41-50.
- Matin, K., and Kuddus, M. (2001). Varietal resistance to bacterial wilt in tomato. *Plant Disease. Rep.* **60**: 120-123.
- Mayavel, A., Balakrishnamurthy, G. and Natarajan, S. (2005). Variability and heritability studies in tomato hybrids. *South Indian Hort.* **53**(1-6): 262-266.

- McCormick, S., Niedermeyer, J., Fry, J.J., Barnason, A., Worsch, R. and Fraley, R. (1986). Leaf disc transformation of cultivated tomato (*Lycopersicon esculentum* Mill.) using *Agrobacterium tumefaciens*. *Plant Cell Rep.* **5**: 81-84.
- Meena, O.P. and Bahadur, V. (2015). Genetic association analysis for fruit yield and its contributing traits of indeterminate tomato (*Solanum lycopersicum* L.) germplasm under open field condition. *J. Agric. Sci.* **7**(3): 148-163.
- Megha, U., Singh, J.P., Singh, A. and Joshi, A. (2006). Studies on genetic variability in tomato (*Solanum lycopersicum* L.). *Progr. Hort.* **3**(2): 463- 465.
- Miller, J.C. and Tanksley, S.D. (1990). RFLP analysis of phylogenetic relationships and genetic variation in the genus (*Lycopersicon esculentum* Mill.). *J. Appl. Genet.* **80**: 437-448.
- Miller, P. (1754). The gardener's dictionary, Abridged 4th ed. London: John and James Rivington.
- Mittal, P., Prakash, S. and Singh, A.K. (1996). Variability studies in tomato (*Lycopersicon esculentum* Mill.) under sub-humid condition of Himachal Pradesh. *South Indian Hort.* **44**: 132-148.
- Mohamed, S.M., Ali, E.E. and Mohamed, T.Y. (2012). Study of Heritability and Genetic Variability among Different Plant and Fruit Characters of Tomato (*Solanum lycopersicum* L.). *Intl. J. Sci. Technol. Res.* **1**(2): 55-58.
- Mohanty, B.K. (2003). Genetic variability, correlation and path coefficient studies in tomato. *Indian J. Agril. Res.* **37**(1): 68-71.
- Mohanty, B.K. and Prusti, A.M. (2001). Analysis of genetic distance in tomato. *Res. Crops.* **2**(3): 382-385.
- Monamodi, E.L., Lungu, D.M. and Fite, G.L. (2013). Analysis of fruit yield and its components in determinate tomato (*Lycopersicon esculentum* Mill.) using correlation and path coefficient. *Bot. J. Agric. Appl. Sci.* **9**(1): 29-40.
- Nahar, K., and Ullah, S.M. (2011). Effect of water stress on moisture content distribution in soil and morphological characters of two tomato (*Lycopersicon esculentum* Mill.) cultivars. *J. Sci. Res.* **3**(3): 677-682.
- Naidu, D.Y. (1993). Study of segregating populations in tomato (*Solanum lycopersicum* L.). *M.Sc Thesis. Uni. Agric. Sci. Dharwad (India)*.

- Naime, J. (2016). Genetic diversity analysis among some tomato genotypes (*Solanum lycopersicum* L.). MS thesis, Shere-e-bangla Agricultural University, Dhaka, Bangladesh.
- Nalla, M.K., Rana, M.K., Singh, S.J., Sinha, A.K., Reddy, P.K. and Mohapatra, P.P. (2014). Assessment of genetic diversity through D² analysis in tomato (*Solanum lycopersicon* .L) *Intl. J. Innovation Appl. Studies*. **6**(3): 431-438.
- Nandpuri, K.S., Kanwar, J.S. and Roshanlal. (1977). Variability path analysis and discriminate function selection in tamato (*Solanum lycopersicum* L.). *Haryana J. Hon. Sci.* **6**: 73-78.
- Narolia, R.K., Reddy, R.V.S.K. and Padma, M. (2012). Correlation, path coefficient and genetic divergence analysis of growth, yield and quality of tomato (*Lycopersicon esculentum* Mill.). *Indian J. Crop Biodiversity*. **20**(1): 65-69.
- Naz, S., Zafrullah, A., Shahzadhi, K. and Munir, N. (2013). Assessment of genetic diversity within germplasm accessions in tomato using morphological and molecular markers. *J. Animal Plant Sci.* **23**(4): 1099-1106.
- Nechifor, B., Filimon, R. and Szilagyi, L. (2011). (Genetic variability, heritability and expected genetic advance as indices for yield and yield components selection in common bean (*phaseolus vulgaris* L.). UASVM Bucharest, Series A: Scientific Papers. 54.
- Nesgea, S., Krishnappa, K.S. and Raju, T.B. (2002). Correlation coefficient analysis in tomato. *Current Res. Univ. Agric. Sci.* **31**(7-8): 127-130.
- Nessa, J., Rahman, L. and Alam, M.S. (2000). Comperative performance of ten genotypes of tomato in late planting. *Bangladesh J. Agric. Sci.* **27**(1): 121-124.
- Norman, J.C. (1974). Some observation of the performance of 13 tomato cultivars of Kuman, Ghuna. *J. Agric. Sci. p.* 51-56.
- Nsowah, C.F. (1970). Preliminary studies of tomato processing varieties at Wenchi, Ghana. *J. Agric. Sci.* **3**(2): 199-201.
- Nur-unnahar (2015). Character association, path and diversity analysis of tomato (*Solanum lycopersicum* L.) MS thesis, Shere-e-bangla Agricultural University, Dhaka, Bangladesh.
- Osei, M.K., Bonsu, K.O., Agyeman, A. and Choi, H.S. (2014). Genetic diversity of tomato germplasm in Ghana using morphological characters. *Intl. J. Plant Soil Sci.* **3**(3): 220–231.

- Padda, D.S., Saibhi, M.S. and Singh, S. (2007). Genotypic and phenotypic variabilities and correlations in quality characters of tomato (*Solanum lycopersicum* L.). *Indian J. Agric. Sci.* **41**: 199-202.
- Padma, E., Ravisankar, C. and Srinivasulu, R. (2002). Correlation and path coefficient studies in tomato (*Lycopersicon esculentum* Mill.). *J. Res. Agric.Sci.* **30**(4): 68-71.
- Padmini, K. and Vadivel, E. (1997). Studies on genetic variability and heritability in F₂ generation of tomato (*Lycopersicon esculentum* Mill.). *South Indian Hort.* **45**(1-2): 1-4.
- Pandit, A., Rai, V. and Bal, S. (2010). Combining QTL mapping and transcriptome profiling of bulked RILs for identification of functional polymorphism for salt tolerance genes in rice (*Oryza sativa* L.). *Mol. Genet. Genomics.* **284**: 121-36.
- Parthasarathy, V.A. and Aswath, E. (2002). Genetic diversity among tomato genotype. *South Indian J. Hort.* **59**(2): 162-166.
- Parvinder, S., Surjan, S., Cheema, D.S., Dhaliwal, M.S. and Singh, S. (2002). Genetic variability and correlation study of some heat tolerant tomato genotypes. *Veg. Sci.* **29**(1): 68-70.
- Patil, A.A. and Bojappa, K.M. (1993). Studies on phenotypic and genotypic correlation on growth, yield and quality attributes in tomato (*Lycopersicon esculentum* Mill.). *Karnataka J. Agric. Sci.* **6**: 133-136.
- Paul, M.R.R., Mojumder, R.R., Khatun, H., Ali, L. and Roy, R.K. (2014). Genetic variability and character association in tomato (*Solanum lycopersicum* L.). *J. Eco-friendly Agril.* **7**(10): 100-104.
- Peralta, I.E., Spooner, D.M. (2001). Granule-bound starch synthase (GBSSI) gene phylogeny of wild tomatoes (*Solanum* L. section *Lycopersicon* (Mill.) Wettst. subsection *Lycopersicon*)". *American J. Bot.* **88**(10): 1888-1902.
- Ponnusviamy, V. and Muthukrishnan, E.R. (2010). A study of inter and intra generation correlation coefficients in F₂ and F₃ generation of tomato. *South Indian Hort.* **25**: 39-43.
- Pradeepkumar, T., Joy, D.B.M., Radhakrishnan, N.V. and Aipe, K.C. (2001). Genetic variation in tomato for yield and resistance to Bacterial Wilt. *J. Trop. Agric.* **39**: 157-158.

- Prasad, V.S.R. and Mathura, R. (2001). Genetic variability, components association and direct and indirect selection in some exotic tomato germplasm. *Indian J. Hort.* **56**(3): 262-266.
- Prashanth, S.J. (2008). Genetic variability and divergence study in tomato (*Lycopersicon esculentum* Mill.). M. Sc. (Agri.) Thesis, Univ. Agric. Sci., Dharwad (India). pp.595-598.
- Pujari, C.V., Wagh, R.S. and Kale, P.N. (1995). Genetic variability and heritability in tomato. *J. Maharashtra Agric. Uni.* **20**(1): 15-17.
- Rani, C.I., Muthuvel, I. and Veer, D. (2010). Correlation and path coefficient for yield components and quality traits in tomato (*Lycopersicon esculentum* Mill.). *Agric. Sci. Digest.* **30**(1): 11-14.
- Rath, P.C. and Math, P. (2001). Screening of some tomato genotypes for susceptibility to the fruit borer. *Veg. Sci.* **24**(2): 153-156.
- Reddy, B.R., Reddy, M.P., Reddy, D.S. and Begum, H. (2013). Correlation and path analysis studies for yield and quality traits in tomato (*Solanum lycopersicum* L.). *IOSR J. Agric. Vet. Sci.* **4**: 56-59.
- Reddy, V.V.P. and Reddy, K.V. (1992). Studies in variability in tomato. *South Indian Hort.* **40**: 257-260.
- Rick, C.M. (1969). Origin of cultivated tomato, current status of the problem. *Intl. Bot. Congress.* p. 180.
- Rick, C.M. (1976). Tomato. Evaluation of Crop Plant. London. pp. 268-273.
- Rick, C.M. and Chetelat, R.T. (1995). Utilization of related wild species for tomato improvement. *Acta Hort.* **412**: 145-154.
- Sachan, M.N. (2001) Heterosis, combining ability, RAPD analysis and resistance breeding to leaf curl viruses and bacterial wilt in tomato (*Solanum lycopersicum* L.). M. Sc. (Agri.) Thesis. Uni. Agric. Sci. Dharwad (India).
- Saeed, A., Hayat, K., Khan, A. A., Iqbal, S. and Abbas, G. (2007). Assessment of genetic variability and heritability in tomato (*Lycopersicon esculentum* Mill.). *Intl. J. Agric. Biol.* **9**(2): 375-377.
- Sahu, G.S. and Mishra, R.S. (1995). Genetic divergence in tomato. *Mysore J. Agric. Sci.* **29**: 5-8.

- Saleem, M.Y., Asghar, M., Iqbal, Q., Rahman, A. and Akram M. (2013). Diallel analysis of yield and some yield components in tomato (*Solanum lycopersicum* L.). *Pakistan J. Bot.* **45**: 1247-1250.
- Saleem, M.Y., Iqbal, Q. and Asghar, M. (2013). Genetic variability, heritability, character association and path analysis in F₁ hybrids of tomato. *Pakistan J. Agri. Sci.* **50**(4): 649-653.
- Samadia, D.K., Aswani, R.C. and Dhandar, G. (2006). Genetic analysis for yield components in tomato land races. *Haryana J. Hort. Sci.* **35**(1-2): 116-119.
- Sharma, K.C. and Verma, S. (2001). Analysis of genetic divergence in tomato. *Annals. Agric. Res.* **22**(1): 71-73.
- Sharma, S.K. and Rastogi, K.B. (1993). Evaluation of some tomato cultivars for seed production under mid hill condition of Himachal Pradesh. *Annals. Agril. Res.* **14**(4): 494-496.
- Shashikanth, P., Das, K. and Mulal, K. (2010). Studies on tomato leaf curl virus. *Indian J. Virol.* **15**: 115-117.
- Shravan, K., Biswash, C. and Mollik, P. (2004). Heterosis and inbreeding depression in tomato. *Utter Pradesh Indian J.* **60**: 139-144.
- Shuaib, M., Alam, Z., Zahir, A., Waqar, A., Taufiq, A. and Ikhtiar, K. (2007). Characterization of wheat varieties by seed storage protein electrophoresis. *African J. Biotechnol.* **6**: 497-500.
- Sidhu, A.S. and Singh, S. (1989). Genetic variability and correlation for yield and quality characters in tomato (*Lycopersicon esculentum* Mill.). *Indian J. Agric. Sci.* **59**(12): 810- 812.
- Silva, P.F., Silva, A.C., Tavares, K.N. and Santos, D.P. (2012). Production and brix degrees content of tomato irrigated with water of different saline concentrations. *Rev. Verde Agroec. Des. Sust.* **7**(4): 85-89.
- Simandle, P.A., Brogdon, J.L., Sweeney, J.P., Mobley, E.O., and Davis, D.W. (1966). Quality of 6 tomato varieties as affected by some compositional factors. *American soci. Hort. Sci.* **89**: 532.
- Singh, B.D. (2009). *Plant Breeding Principles and Methods*, Kalyani Publisher, New Delhi, India.
- Singh, D.N., Sahu, A. and Parida, A.K. (1997). Genetic variability and correlation studies in tomato (*Lycopersicon esculentum* Mill.). *Environ. Ecol.* **15**(1): 117-121.

- Singh, H. and Cheema, D.S. (2006). Correlation and path coefficient studies in tomato (*Lycopersicon esculentum* Mill.). *Haryana J. Hort. Sci.* **35**(1-2): 126-129.
- Singh, J.K., Singh, J.P., Jain, S.K., Joshi, A. and Joshi, K. (2002). Studies on genetic variability and its importance in tomato (*Solanum lycopersicum* L.). *Progr. Hort.* **34**(1): 77-79.
- Singh, J.P., Singh, A. and Joshi, A. (2005). Studies on genetic variability in tomato (*Lycopersicon esculentum* Mill.). *Prog. Hort.* **37**(2): 463-465.
- Singh, P.K., Singh, R.K., Saha, B.C. and Rajeshkumar, (1989). Genetic variability in tomato. *Indian J. Agric. Sci.* **58**: 718-720.
- Singh, R.K. and Choudhary, B.D. (1985). Biometrical methods of quantitative genetic analysis. *Haryana J. Hort. Sci.* **12**(2): 151-156.
- Singh, R.K. and Singh, V.K. (1993). Heterosis breeding in tomato. *Ann. Agric. Res.* **14**(4): 4
- Singh, R.R., Mital, R.K. and Singh, H.N. (1973). Note on variability studies in some inter varietal crosses of tomato (*Solanum lycopersicum* L.). *Indian J. Genet. Plant Breed.* **38**: 330-335.
- Smith, A.F. (1994). *The Tomato in America: Early History, Culture, and Cookery.* Columbia SC, USA: University of South Carolina Press. ISBN 1-57003-000-6.
- Stevens, M.A., Kader, A.A., Albright-Holton, M. (1972). Intercultivar variation in composition of locular and pericarp portions of fresh market tomatoes. *J. Animal Soci. Hortic. Sci.* **102**: 689-692.
- Supe, V.S. and Kale, P.B. (1992). Correlation and path analysis in tomato. *J. Maharashtra Agric. Univ.* **17**: 331-333.
- Thakur, B.S. (2009). Adaptability of tomato genotypes under mid-hill conditions of Himachal Pradesh. *Haryana J. Hort. Sci.* **38**(1-2): 93-95.
- Upadhyay, R., Lal, G. and Ram, H.H. (2005). Genotype environment interaction and stability analysis in tomato. *Prog. Hort.* **33**(2): 190-193.
- Vavilov, N.I. (1951). The origin, variation, immunity and breeding of cultivated plants. *Chronica Bot.* **13**: 1-366.
- Verma, S.K. and Sarnaik, D.A. (2000). Path analysis of yield components in tomato (*Lycopersicon esculentum* Mill.). *J. Appl. Biol.* **10**(2): 136-138.

- Weber, C.R. and Moorthy, H.R. (2010). Heritable and non-heritable relationship and variability of oil content and agronomic characters in the F₂ generation of soybean crosses. *Agron. J.* **44**: 202-209.
- Wright, S. (2007). Correlation and causation. *J. Agric. Res.* **20**: 202-209.
- YaDong, S., Yan, L., JiangMin, W., Lei, L. and XiaoJing W. (2010). Correlation analysis on quantitative traits of tomato germplasm resources. *China Veg.* **15**(6): 74-76.

APPENDICES

Appendix I. Map showing the experimental site under the study

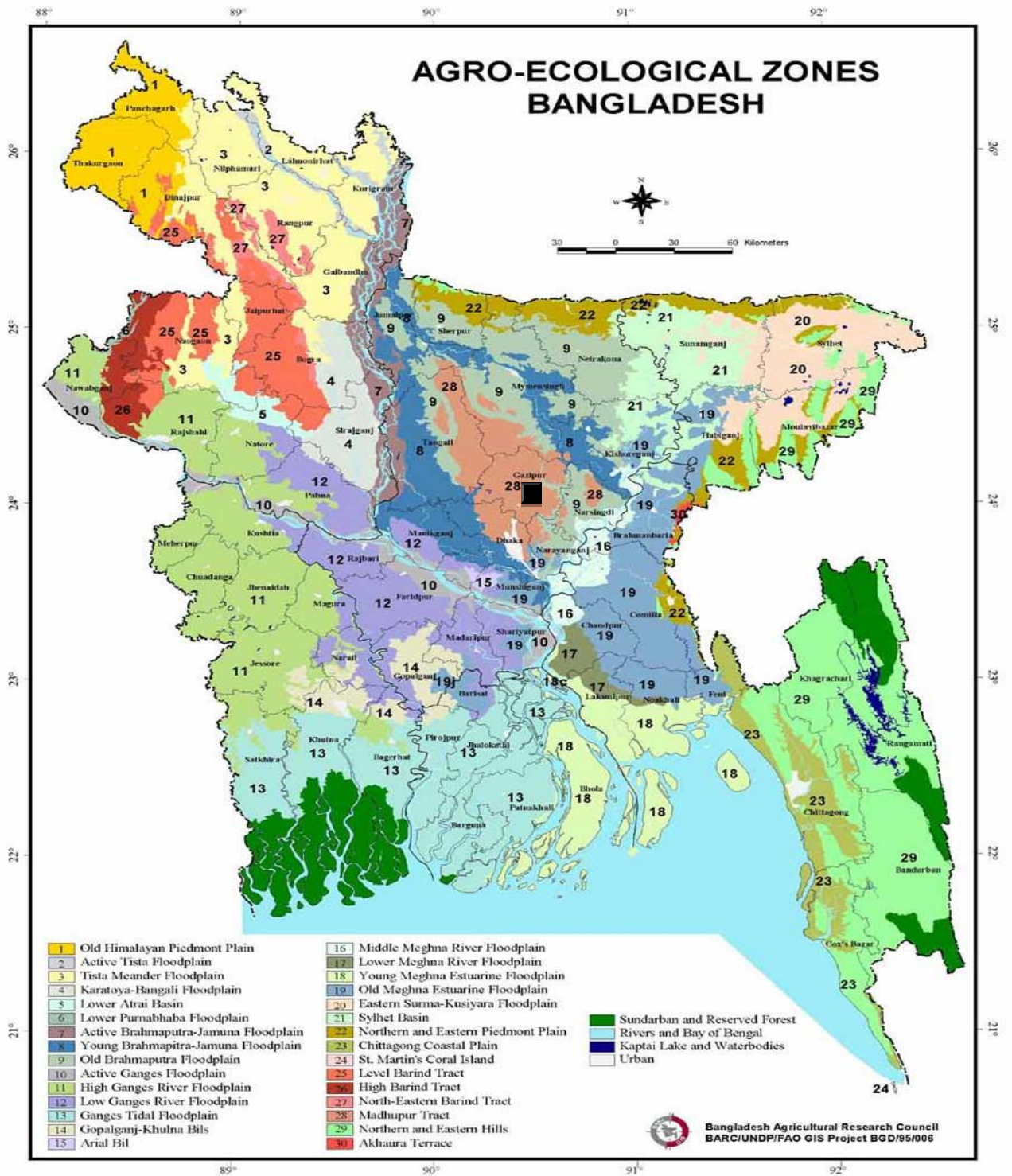

■ Experimental area under study

Appendix II. Morphological, physical and chemical characteristics of initial soil (0- 15 cm depth) of the experimental site

A. Morphological characteristics of the experimental field

Morphological features	Characteristics
Location	Sher-e-Bangla Agricultural University Research Farm, Dhaka
AEZ	AEZ-28, Modhupur Tract
General Soil Type	Deep Red Brown Terrace Soil
Land type	High land
Soil series	Tejgaon
Topography	Fairly leveled

B. Physical composition of the soil

Soil separates	%	Methods employed
Sand	36.90	Hydrometer method (Day, 1915)
Silt	26.40	Do
Clay	36.66	Do
Texture class	Clay loam	Do

C. Chemical composition of the soil

Sl. No.	Soil characteristics	Analytical data	Methods employed
1	Organic carbon (%)	0.45	Walkley and Black, 1947
2	Total N (%)	0.03	Bremner and Mulvaney, 1965
3	Total S (ppm)	225.00	Bardsley and Lanester, 1965
4	Total P (ppm)	840.00	Olsen and Sommers, 1982
5	Available N (kg/ha)	54.00	Bremner, 1965
6	Available P (ppm)	20.54	Olsen and Dean, 1965
7	Exchangeable K (me/100 g soil)	0.10	Pratt, 1965
8	Available S (ppm)	16.00	Hunter, 1984
9	pH (1:2.5 soil to water)	5.6	Jackson, 1958
10	CEC	11.23	Chapman, 1965

Source: Soil Resource and Development Institute (SRDI), Farmgate, Dhaka.

Appendix III. Monthly records of air temperature, relative humidity, rainfall and sunshine hours of the experimental site during the period from November 2019 to March 2020

Month	Year	Monthly average air temperature (° C)			Average relative humidity (%)	Total rainfall (mm)	Total sunshine (hours)
		Maximum	Minimum	Mean			
Nov	2019	24.9	18.5	21.7	74	37	216.4
Dec	2019	19.3	15.5	17.4	74	5	212.50
Jan	2020	18.5	15	16.75	76	21	212.50
Feb	2020	21.6	18	19.8	59	1	195.00
Mar	2020	26.4	18.5	22.45	57	30	225.50

Source: Bangladesh Meteorological Department (Climate division), Agargaon, Dhaka-1212.

Appendix IV. Layout of the experimental design

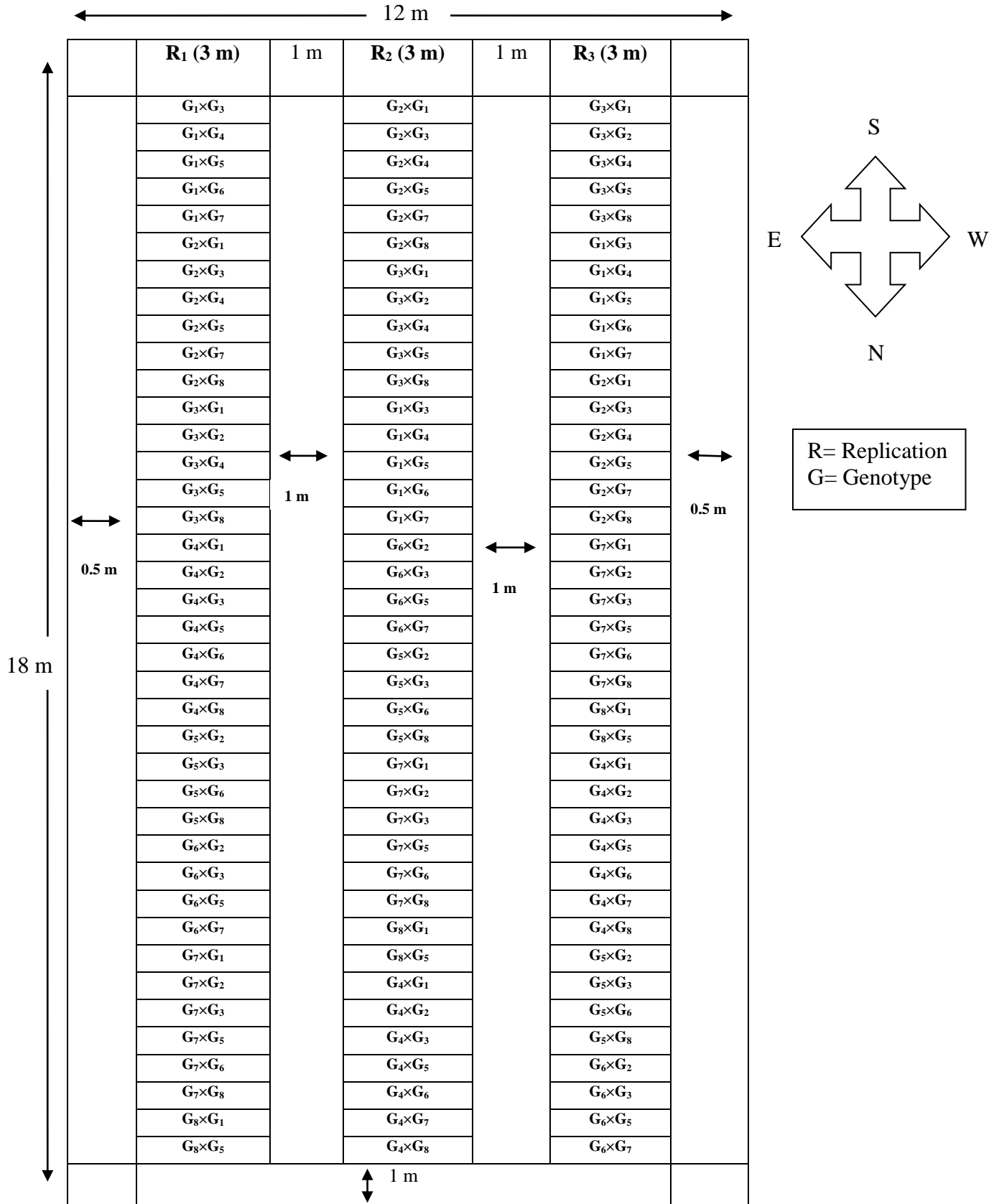

Appendix V. Analysis of variance for 20 characters of 39 tomato genotypes

Characters	Mean sum of square			
	Replication (r-1) = 2	Genotype (g-1) = 38	Error (r-1)(g-1) = 76	CV(%)
Days to first flowering	107.34	54.05**	26.84	13.74
Days to 50% flowering	0.33	35.18**	2.11	1.89
Days to first fruiting	176.78	105.44**	43.54	10.81
Days to maturity	8.52	130.12**	7.32	2.72
Plant height (cm)	301.39	131.86**	64.12	9.12
No. of branches per plant	2.37	3.21**	1.70	13.37
No. of clusters per plant	12.57	25.68**	10.74	16.41
No. of flowers per cluster	0.23	1.86*	1.18	14.60
No. of fruits per cluster	0.52	1.50**	0.41	10.65
No. of fruits per plant	79.39	1513.21**	536.71	19.33
Fruit length (cm)	34.58	143.97**	12.24	18.20
Fruit diameter (cm)	5.49	140.22**	10.92	15.71
Skin diameter (mm)	0.07	1.51**	0.19	9.89
Locule number	0.44	4.75**	0.32	18.69
Total soluble solids	0.003	5.73**	0.003	1.95
pH	0.03	0.70**	0.002	0.94
Relative water content	1.44	306.13**	5.91	3.20
Moisture percentage	0.26	9.64**	0.25	0.51
Individual fruit weight (g)	6.24	377.76**	0.52	2.57
Yield per plant (kg)	0.10	2.28**	0.30	17.25

** Denote Significant at 1% level of probability *Denote Significant at 5% level of probability; CV (%) = Coefficient of variation.

Appendix VI. Mean performance of various growth parameters and yield components of 39 genotypes of tomato

Genotypes	DFF	DFFP	DFFr	DM	PH	NBP	NCP	NFC	NFrC	NFrP
G ₁ × G ₃	44.00 ab	78.33 d-h	62.00 a-i	104.00 bc	95.45 ab	8.33 e-g	16.667 e-h	6.33 cd	5.33 d-g	88.33 k-m
G ₁ × G ₄	41.00 a-d	73.67 k-m	53.33 g-j	90.33 f	75.89 hi	9.33 b-g	16.00 gh	6.6667 b-d	4.67 fg	74.33 m
G ₁ × G ₅	39.00 a-e	78.67 c-g	61.67 a-i	107.67 ab	96.00 ab	10.33 a-e	23.33 b	7.0000 b-d	6.00 b-e	140.00 b-g
G ₁ × G ₆	43.33 a-c	78.333d-h	63.333 a-g	105.00 ab	91.00a-e	11.00a-c	20.33b-h	6.33cd	6.00 b-e	122.00 c-k
G ₁ × G ₇	38.33 a-e	77.67 e-i	59.33 d-j	104.00 bc	95.89 ab	11.00 a-c	18.67 b-h	6.00 d	5.67 c-f	106.00 g-m
G ₂ × G ₁	35.67 b-f	73.67 k-m	51.33 ij	90.33 f	76.34 g-i	8.00 fg	16.33 f-h	7.00 b-d	4.67 fg	75.67 lm
G ₂ × G ₃	35.33c-f	78.67c-g	58.33d-j	104.00bc	84.89b-i	9.00c-g	23.00bc	6.33cd	5.67 c-f	132.33 b-i
G ₂ × G ₄	37.67 a-e	73.00 lm	64.33 a-f	90.33 f	80.78 d-i	9.67 b-g	16.00 gh	6.00 d	5.67 c-f	90.33 j-m
Min	24.333	72	49.33	89.67	72.00	7.67	15.33	6	4.33	74.33
Max	44.333	82	72	109	99.56	12	30	9.33	7.33	180
Mean	37.701	76.92	61.07	99.61	87.80	9.75	19.97	7.44	5.99	119.83
LSD (%)	8.4252	2.36	10.73	4.40	13.02	2.12	5.33	1.77	0.521	37.674

Note: DFF= Days to first flowering, DFFP= Days to 50% flowering, DFFr= Days to first fruiting, DM= Days to maturity, PH= Plant height (cm), NBP= No. of branches per plant, NCP= No. of clusters per plant, NFC= No. of flowers per cluster, NFrC= No. of fruits per cluster, NFrP= No. of fruits per plant.

Appendix VI. Cont'd

Genotypes	DFE	DFPF	DFFr	DM	PH	NBP	NCP	NFC	NFrC	NFrP
G₂ × G₅	36.33 a-e	73.00 lm	68.67 a-d	89.67 f	94.340 a-c	10.00 a-f	21.00 b-g	6.33 cd	4.33 g	91.33 j-m
G₂ × G₇	39.67 a-d	72.00 m	51.33 ij	92.00 f	87.34 a-h	9.67 b-g	18.00 c-h	9.33 a	6.00 b-e	108.00 f-m
G₂ × G₈	33.00 d-f	77.67 e-i	52.00 h-j	90.33 f	94.11 a-c	9.00 c-g	22.33 b-d	7.00 b-d	5.00 e-g	111.67 c-m
G₃ × G₁	44.33 a	79.33 b-g	58.67 d-j	104.00 bc	87.34 a-h	10.33 a-e	30.00 a	7.67 a-d	6.00 b-e	180.00 a
G₃ × G₂	37.00 a-e	72.00 m	56.00 f-j	92.00 f	82.12 c-i	10.00 a-f	18.00 c-h	8.3333 ab	7.00 ab	124.00 c-k
G₃ × G₄	36.67 a-e	81.00 a-c	57.33 e-j	104.00 bc	93.67 a-d	11.33 ab	22.33 b-d	7.33 b-d	6.67 a-c	148.00 a-d
G₃ × G₅	37.33 a-e	81.333 ab	61.000 b-i	104.00 bc	92.34 a-d	8.67 d-g	23.33 b	7.67 a-d	6.33 a-d	148.33 a-c
G₃ × G₈	40.00 a-d	81.00 a-c	63.00 a-g	104.00 bc	88.22 a-h	10.00 a-f	17.67 d-h	7.67 a-d	6.33 a-d	110.33 d-m
Min	24.333	72	49.33	89.67	72.00	7.67	15.33	6	4.33	74.33
Max	44.333	82	72	109	99.56	12	30	9.33	7.33	180
Mean	37.701	76.92	61.07	99.61	87.80	9.75	19.97	7.44	5.99	119.83
LSD (%)	8.4252	2.36	10.73	4.40	13.02	2.12	5.33	1.77	0.521	37.674

Note: DFE= Days to first flowering, DFPF= Days to 50% flowering, DFFr= Days to first fruiting, DM= Days to maturity, PH= Plant height (cm), NBP= No. of branches per plant, NCP= No. of clusters per plant, NFC= No. of flowers per cluster, NFrC= No. of fruits per cluster, NFrP= No. of fruits per plant.

Appendix VI. Cont'd

Genotypes	DFE	DFPF	DFFr	DM	PH	NBP	NCP	NFC	NFrC	NFrP
G₄ × G₁	39.67 a-d	80.67 a-d	71.33 a-c	109.00 a	89.24 a-g	9.33 b-g	22.33 b-d	8.33 ab	6.33 a-d	141.33 b-g
G₄ × G₂	39.67 a-d	79.33 b-g	65.33 a-f	107.00 ab	91.56 a-d	9.67 b-g	21.67 b-e	7.33 b-d	6.00 b-e	130.00 b-i
G₄ × G₃	39.33 a-d	80.00 a-e	66.00 a-f	106.33 ab	92.56 a-d	11.00 a-c	21.33 b-f	7.33 b-d	6.33 a-d	134.00 b-i
G₄ × G₅	39.67 a-d	73.00 lm	62.33 a-h	98.00 e	72.00 i	7.667 g	21.00 b-g	9.33 a	5.67 c-f	119.33 c-k
G₄ × G₆	38.00 a-e	73.00 lm	58.00 d-j	98.00 e	83.23 b-i	10.33 a-e	21.00 b-g	7.33 b-d	5.67 c-f	118.67 c-k
G₄ × G₇	40.00 a-d	73.00 lm	63.67 a-g	98.00 e	93.34 a-d	9.33 b-g	23.33 b	7.33 b-d	7.00 ab	162.67 ab
G₄ × G₈	42.00 a-c	74.67 j-l	63.00 a-g	90.00 f	94.56 a-c	9.67 b-g	15.33 h	7.67 a-d	7.00 ab	109.33 e-m
G₅ × G₂	42.33 a-c	80.00 a-e	71.67 ab	103.67 b-d	89.56 a-f	9.00 c-g	21.33 b-f	8.00 a-c	5.67 c-f	137.33 b-h
Min	24.333	72	49.33	89.67	72.00	7.67	15.33	6	4.33	74.33
Max	44.333	82	72	109	99.56	12	30	9.33	7.33	180
Mean	37.701	76.92	61.07	99.61	87.80	9.75	19.97	7.44	5.99	119.83
LSD (%)	8.4252	2.36	10.73	4.40	13.02	2.12	5.33	1.77	0.521	37.674

Note: DFE= Days to first flowering, DFPF= Days to 50% flowering, DFFr= Days to first fruiting, DM= Days to maturity, PH= Plant height (cm), NBP= No. of branches per plant, NCP= No. of clusters per plant, NFC= No. of flowers per cluster, NFrC= No. of fruits per cluster, NFrP= No. of fruits per plant.

Appendix VI. Cont'd

Genotypes	DFE	DFPF	DFFr	DM	PH	NBP	NCP	NFC	NfrC	NFrP
G₅ × G₃	43.00 a-c	80.67 a-d	67.67 a-e	103.67 b-d	92.12 a-d	9.667 b-g	17.33 d-h	7.00 b-d	6.00 b-e	104.00 g-m
G₅ × G₆	38.33 a-e	77.00 g-j	65.33 a-f	105.67 ab	86.56 a-h	9.00 c-g	23.00 bc	7.33 b-d	6.33 a-d	146.33 a-e
G₅ × G₈	41.67 a-c	80.67 a-d	65.67 a-f	104.00 bc	77.67 f-i	10.33 a-e	19.00 b-h	7.00 b-d	6.67 a-c	127.00 b-j
G₆ × G₂	38.33 a-e	80.67 a-d	57.33 e-j	107.67 ab	84.34 b-i	8.33 e-g	19.33 b-h	7.33 b-d	6.67 a-c	128.00 b-j
G₆ × G₃	36.667 a-e	82.000 a	61.000 b-i	104.00 bc	77.557 f-i	12.000 a	20.33 b-h	7.3333 b-d	5.33 d-g	108.33 f-m
G₆ × G₅	36.33 a-e	73.00 lm	60.67 c-i	91.33 f	83.89 b-i	10.33 a-e	16.00 gh	8.00 a-c	7.33 a	117.33 c-k
G₆ × G₇	32.67 d-g	72.00 m	49.33 j	90.33 f	78.00 e-i	8.67 d-g	18.33 b-h	7.33 b-d	5.33 d-g	97.33 i-m
G₇ × G₁	37.67 a-e	77.00 g-j	72.00 a	103.67 b-d	84.67 b-i	12.00 a	22.33 b-d	8.33 ab	6.67 a-c	145.33 a-f
Min	24.333	72	49.33	89.67	72.00	7.67	15.33	6	4.33	74.33
Max	44.333	82	72	109	99.56	12	30	9.33	7.33	180
Mean	37.701	76.92	61.07	99.61	87.80	9.75	19.97	7.44	5.99	119.83
LSD (%)	8.4252	2.36	10.73	4.40	13.02	2.12	5.33	1.77	0.521	37.674

Note: DFE= Days to first flowering, DFPF= Days to 50% flowering, DFFr= Days to first fruiting, DM= Days to maturity, PH= Plant height (cm), NBP= No. of branches per plant, NCP= No. of clusters per plant, NFC= No. of flowers per cluster, NfrC= No. of fruits per cluster, NFrP= No. of fruits per plant.

Appendix VI. Cont'd

Genotypes	DFE	DFPF	DFFr	DM	PH	NBP	NCP	NFC	NfrC	NFrP
G₇ × G₂	37.67 a-e	76.00 h-k	59.33 d-j	90.33 f	87.22 a-h	9.67 b-g	18.00 c-h	8.00 a-c	7.00 ab	127.00 b-j
G₇ × G₃	30.67 e-g	72.00 m	62.33 a-h	99.33 de	90.34 a-f	10.00 a-f	18.73 b-h	8.33 ab	6.00 b-e	112.47 c-l
G₇ × G₅	24.33 g	75.67 i-k	67.67 a-e	90.33 f	85.12 b-h	8.00 fg	21.00 b-g	7.33 b-d	5.33 d-g	111.67 c-m
G₇ × G₆	30.67 e-g	72.00 m	49.33 j	99.67 c-e	91.56 a-d	10.67 ad	20.33 b-h	8.33 ab	5.33 d-g	108.67 e-m
G₇ × G₈	37.000 a-e	77.333 f-i	59.000 d-j	104.00 bc	88.893 a-h	9.667 b-g	16.67 e-h	7.6667 a-d	6.67 a-c	109.33 e-m
G₈ × G₁	27.67 fg	79.67 a-f	56.33 f-j	99.33 de	99.56 a	10.67 a-d	20.00 b-h	7.00 b-d	6.33 a-d	126.00 b-k
G₈ × G₅	38.33 a-e	81.33 ab	65.67 a-f	105.67 ab	94.89 a-c	9.67 b-g	18.00 c-h	8.00 a-c	5.67 c-f	101.33 h-m
Min	24.333	72	49.33	89.67	72.00	7.67	15.33	6	4.33	74.33
Max	44.333	82	72	109	99.56	12	30	9.33	7.33	180
Mean	37.701	76.92	61.07	99.61	87.80	9.75	19.97	7.44	5.99	119.83
LSD (%)	8.4252	2.36	10.73	4.40	13.02	2.12	5.33	1.77	0.521	37.674

Note: DFE= Days to first flowering, DFPF= Days to 50% flowering, DFFr= Days to first fruiting, DM= Days to maturity, PH= Plant height (cm), NBP= No. of branches per plant, NCP= No. of clusters per plant, NFC= No. of flowers per cluster, NfrC= No. of fruits per cluster, NFrP= No. of fruits per plant.

Appendix VI. Cont'd

Genotypes	FL	FD	SD	LN	TSS	pH	RWC	MP	IFrW	YP
G₁ × G₃	18.37 i-n	25.00 d-g	6.17 a	5.67 b	1.00 s	4.53 ij	75.72 l-n	96.54 j-m	43.70 b	3.86 a-f
G₁ × G₄	25.33 c-g	48.00 a	4.34 g-k	8.67 a	1.00 s	3.65 t	72.61 m-o	94.73 p	60.26 a	4.62 a
G₁ × G₅	12.67 o-r	17.67 j-m	4.60 d-i	3.33 d-f	6.37 a	4.41 lm	87.20 a-d	99.92 a	17.13 op	2.40 k-o
G₁ × G₆	12.83 n-r	13.33 m	4.33 g-k	2.33 gh	4.93 c	4.03 r	85.78 a-g	99.95 a	13.87 st	1.68 no
G₁ × G₇	13.67 m-q	16.67 k-m	4.07 i-m	2.00 h	3.07 jk	6.55 a	71.85 no	98.30 d-f	14.90 rs	1.58 o
G₂ × G₁	29.000 b-e	30.33 cd	4.30 g-k	3.33 d-f	1.00 s	4.67 fg	87.48 abc	97.38 g-i	61.00 a	4.60 a
G₂ × G₃	9.33 qr	14.33 lm	3.20 op	2.67 f-h	3.10 j	4.77 d	52.3 1t	96.53 j-m	20.17 n	3.01 f-l
G₂ × G₄	23.33 e-j	27.33 c-e	5.25 b-d	3.33 d-f	2.57 l	4.36 m-o	61.60 rs	96.75 i-l	32.33 f	2.92 g-l
G₂ × G₅	30.50 a-c	18.83 i-l	3.40 m-p	2.00 h	1.00 s	4.67 fg	73.19 l-o	96.10 l-n	32.13 f	2.94 g-l
Min	7.67	13.33	2.9	2	1	3.65	52.31	94.62	13.53	1.54
Max	36	48	6.17	8.67	6.37	6.55	88.79	99.98	61.00	4.62
Mean	19.22	21.03	4.40	3.03	2.60	4.49	75.94	97.94	27.99	3.19
LSD (%)	5.69	5.37	0.71	0.92	0.08	0.07	3.95	0.81	1.169	0.896

Note: FL= Fruit length (cm), FD= Fruit diameter (cm), SD= Skin diameter (mm), LN= Locule number, TSS= Total soluble solids, pH, RWC= Relative water content, MP= Moisture percentage, IFrW= Individual fruit weight (g), YP= Yield per plant (kg).

Appendix VI. Cont'd

Genotypes	FL	FD	SD	LN	TSS	Ph	RWC	MP	IFrW	YP
G₂ × G₇	36.00 a	25.00 d-g	5.20 b-e	2.67 f-h	2.00 n	4.36 m-o	84.96 a-h	96.32 k-m	41.00 c	4.42 a-c
G₂ × G₈	15.33 l-p	15.50 lm	3.57 l-p	2.67 f-h	3.20 i	4.77 de	83.52 c-j	95.36 n-p	26.73 jk	2.99 f-l
G₃ × G₁	13.67 m-q	18.00 j-m	4.25 g-l	2.00 h	4.00 e	4.55 hi	71.55 o	98.12 e-g	17.07 op	3.08 e-l
G₃ × G₂	16.20 k-p	21.50 g-k	3.83 j-o	4.00 cd	1.00 s	4.75 de	60.92 s	98.98 b-d	35.37 d	4.39 a-c
G₃ × G₄	16.03 k-p	21.67 f-k	4.43 f-k	3.00 efg	2.00 n	4.46 kl	55.75 t	95.92 m-o	25.60 kl	3.79 a-g
G₃ × G₅	16.30 k-p	15.23 lm	3.45 m-p	4.33 c	1.27 q	4.15 q	86.20 a-f	98.20 b-d	27.47 ij	4.07 a-d
G₃ × G₈	26.83 b-f	21.33 g-k	5.60 ab	2.33 gh	2.00 n	4.61 gh	82.64 f-j	98.66 de	34.17 e	3.77 a-g
G₄ × G₁	12.00 p-r	16.67 k-m	3.25 n-p	2.33 gh	3.73 f	4.18 q	76.25 k-m	99.51 a-c	15.80 qr	2.23 l-o
G₄ × G₂	11.00 p-r	15.67 lm	4.20 h-l	3.00 e-g	3.77 f	4.12 q	72.64 m-o	99.77 ab	13.53 t	1.75 m-o
Min	7.67	13.33	2.9	2	1	3.65	52.31	94.62	13.53	1.54
Max	36	48	6.17	8.67	6.37	6.55	88.79	99.98	61.00	4.62
Mean	19.22	21.03	4.40	3.03	2.60	4.49	75.94	97.94	27.99	3.19
LSD (%)	5.69	5.37	0.71	0.92	0.08	0.07	3.95	0.81	1.169	0.896

Note: FL= Fruit length (cm), FD= Fruit diameter (cm), SD= Skin diameter (mm), LN= Locule number, TSS= Total soluble solids, pH, RWC= Relative water content, MP= Moisture percentage, IFrW= Individual fruit weight (g), YP= Yield per plant (kg).

Appendix VI. Cont'd

Genotypes	FL	FD	SD	LN	TSS	Ph	RWC	MP	IFrW	YP
G₄ × G₃	15.67 l-p	17.83 j-m	4.80 c-h	2.67 f-h	3.60 g	4.35 m-o	65.19 qr	99.94 a	16.73 pq	2.24 l-o
G₄ × G₅	31.47 ab	27.00 c-f	4.50 e-j	4.00 cd	1.00 s	4.33 n-p	81.11 h-j	98.98 b-d	34.07 e	4.10 a-d
G₄ × G₆	25.00 c-h	18.67 i-m	4.6000 d-i	2.67 f-h	1.10 r	5.08 b	82.05 g-j	99.96 a	33.83 e	4.02 a-d
G₄ × G₇	14.00 m-q	19.67 g-l	4.20 h-l	2.67 f-h	1.50 p	4.48 i-k	82.92 e-j	99.98 a	24.80 lm	4.04 a-d
G₄ × G₈	21.50 f-k	18.87 i-l	4.08 i-m	2.33 gh	3.067 jk	4.700 ef	83.47 d-j	99.97 a	24.80 lm	2.72 h-l
G₅ × G₂	13.67 m-q	17.33 j-m	4.92 b-g	2.33 gh	3.00 k	4.65 fg	88.18 ab	96.95 h-k	24.27 m	3.34 d-j
G₅ × G₃	14.33 l-q	17.83 j-m	4.55 d-i	3.00 e-g	5.10 b	4.63 fg	80.86 ij	98.39 d-f	14.80 rs	1.54 o
G₅ × G₆	14.83 l-q	17.00 k-m	4.65 d-i	2.00 h	4.00 e	4.27 p	86.79 a-e	99.98 a	20.17 n	2.95 g-l
Min	7.67	13.33	2.9	2	1	3.65	52.31	94.62	13.53	1.54
Max	36	48	6.17	8.67	6.37	6.55	88.79	99.98	61.00	4.62
Mean	19.22	21.03	4.40	3.03	2.60	4.49	75.94	97.94	27.99	3.19
LSD (%)	5.69	5.37	0.71	0.92	0.08	0.07	3.95	0.81	1.169	0.896

Note: FL= Fruit length (cm), FD= Fruit diameter (cm), SD= Skin diameter (mm), LN= Locule number, TSS= Total soluble solids, pH, RWC= Relative water content, MP= Moisture percentage, IFrW= Individual fruit weight (g), YP= Yield per plant (kg).

Appendix VI. Cont'd

Genotypes	FL	FD	SD	LN	TSS	Ph	RWC	MP	IFrW	YP
G₅ × G₈	17.93 j-o	19.17 h-l	4.38 f-k	2.00 h	3.50 h	4.40 l-n	67.36 pq	98.04 e-g	20.77 n	2.64 i-m
G₆ × G₂	14.67 l-q	18.67 i-m	4.10 h-m	2.67 f-h	3.00 k	4.67 fg	88.789 a	97.70 f-h	27.93 i	3.573 c-h
G₆ × G₃	7.67 r	15.00 lm	4.60 d-i	3.67 c-e	3.80 f	4.30 op	71.81 no	99.97 a	30.73 gh	3.33 d-j
G₆ × G₅	29.27 b-d	24.33e-h	5.42 bc	2.67 f-h	1.47 p	4.37 mn	70.15 op	95.86 m-o	30.73 gh	3.61 b-h
G₆ × G₇	24.00 d-i	37.33 b	5.06 b-f	5.33 b	1.00 s	5.01 c	55.24 t	94.62 p	35.83 d	3.49 d-i
G₇ × G₁	19.33 h-m	32.33 bc	4.37 f-k	3.00 e-g	1.83 o	3.67 t	80.10 jk	99.66 ab	17.53 op	2.54 j-n
G₇ × G₂	17.83 j-o	16.33 k-m	3.75 k-o	2.33 gh	4.00 e	3.88 s	82.81 f-j	95.82 m-o	27.87 ij	3.54 c-h
Min	7.67	13.33	2.9	2	1	3.65	52.31	94.62	13.53	1.54
Max	36	48	6.17	8.67	6.37	6.55	88.79	99.98	61.00	4.62
Mean	19.22	21.03	4.40	3.03	2.60	4.49	75.94	97.94	27.99	3.19
LSD (%)	5.69	5.37	0.71	0.92	0.08	0.07	3.95	0.81	1.169	0.896

Note: FL= Fruit length (cm), FD= Fruit diameter (cm), SD= Skin diameter (mm), LN= Locule number, TSS= Total soluble solids, pH, RWC= Relative water content, MP= Moisture percentage, IFrW= Individual fruit weight (g), YP= Yield per plant (kg).

Appendix VI. Cont'd

Genotypes	FL	FD	SD	LN	TSS	Ph	RWC	MP	IFrW	YP
G₇ × G₃	27.33 b-e	23.67 e-i	5.52 ab	2.00 h	1.00 s	5.01 c	76.82 kl	97.16 h-j	35.00 de	3.92 a-e
G₇ × G₅	27.67 b-e	19.33 h-l	4.60 d-i	2.33 gh	3.00 k	4.47 j-l	70.76 op	95.16 op	40.17 c	4.49 ab
G₇ × G₆	15.33 l-p	17.00 k-m	2.90 p	3.33 d-f	1.23 q	3.65 t	70.87 op	98.71 c-e	29.63 h	3.22 d-k
G₇ × G₈	25.53 c-g	22.67 e-j	5.22 b-d	3.00 e-g	2.00 n	4.17 q	84.725 b-i	99.976 a	20.47 n	2.22 l-o
G₈ × G₁	14.33 l-q	15.67 lm	3.95 i-n	2.33 gh	4.10 d	4.68 f	63.06 rs	99.68 ab	17.93 o	2.26 l-o
G₈ × G₅	19.87 g-l	22.50 e-j	4.00 i-m	2.33 gh	2.17 m	4.55 hi	86.57 a-f	95.31 n-p	31.37 fg	2.75 h-l
Min	7.67	13.33	2.9	2	1	3.65	52.31	94.62	13.53	1.54
Max	36	48	6.17	8.67	6.37	6.55	88.79	99.98	61.00	4.62
Mean	19.22	21.03	4.40	3.03	2.60	4.49	75.94	97.94	27.99	3.19
LSD (%)	5.69	5.37	0.71	0.92	0.08	0.07	3.95	0.81	1.169	0.896

Note: FL= Fruit length (cm), FD= Fruit diameter (cm), SD= Skin diameter (mm), LN= Locule number, TSS= Total soluble solids, pH, RWC= Relative water content, MP= Moisture percentage, IFrW= Individual fruit weight (g), YP= Yield per plant (kg).

Appendix VII. Pictorial views of the experimental field



Visit of research supervisor in the field